

Panasonic

DVCPRO

DVCPRO Studio VTR

AJ-D850P

Operating Instructions

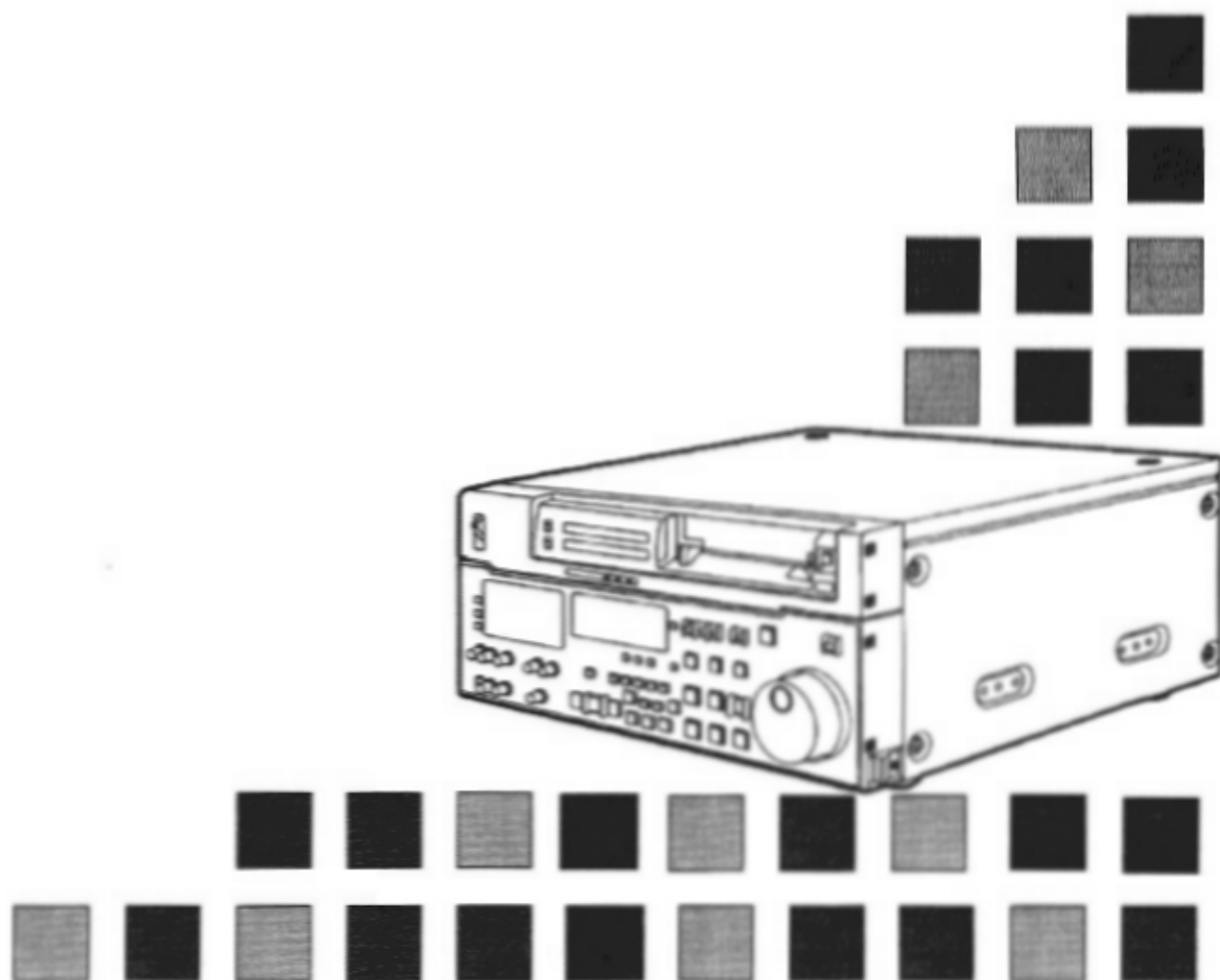

Specifications

GENERAL

Power supply:	AC 120 V, 50 – 60 Hz
Power consumption:	210 W

Operating ambient temperature:	41°F to 104°F (5°C to 40°C)
Operating ambient humidity:	10% to 90% (no condensation)
Weight:	36.96 lbs (16.8 kg)
Dimensions (W × H × D):	16-3/4 × 6-15/16 × 16-3/8 inches
Recording format:	DVCPRO format
Recording tracks:	Digital video Time code; Recorded in sub-code area Digital audio; 2 channels Cue Signal; 1 track Control (CTL); 1 track
Tape speed:	33.820 mm/sec
Recording time:	184 minutes (with AJ-5P92LP) 66 minutes (with AJ-P66MP)
Tape:	1/4-inch thin magnetic layer metal tape
FF/REW time:	Less than 3 minutes (with AJ-5P92LP) Less than 2 minutes (with AJ-P66MP)
Editing accuracy:	±0 frame (using time code)
Tape timer accuracy:	±1 frame (using continuous CTL signal)
Servo lock time:	Less than 0.5 sec. (color framing/ standby ON)

VIDEO

(Digital video)

Sampling frequencies:	Y; 13.5 MHz/Pb, Pr; 3.375 MHz
Quantizing:	8 bits
Error correction:	Reed-Solomon product code

(Digital IN/analog component OUT)

Video bandwidth:	Y; 30 Hz to 5.5 MHz (±0.5 dB) 5.75 MHz (-2 dB) Pb, Pr; 30 Hz to 1.3 MHz (±1 dB) 1.5 MHz (-5 dB) typ.
-------------------------	---

S/N ratio:	Better than 60 dB
K factor:	Less than 1%

(Analog component IN/component OUT)

Video bandwidth:	Y; 30 Hz to 5.5 MHz (±1 dB) 5.75 MHz (-3 dB) Pb, Pr; 30 Hz to 1.3 MHz (±1 dB) 1.5 MHz (-6 dB) typ.
-------------------------	---

S/N ratio:	Better than 55 dB
K factor:	Less than 1%

(Analog composite IN/composite OUT)

Video bandwidth:	Y; 30 Hz to 4.5 MHz (±1 dB)
DG:	Less than 4%
DP:	Less than 3°
Y/C delay:	Better than 20 nsec
K factor:	Less than 2%

(Video input connector)

Analog component input:	BNC×3 (Y, Pb, Pr) Y; 1.0 Vp-p, 75Ω Pb, Pr; 0.486/0.7 Vp-p switchable, 75Ω (75% color bar, 7.5% setup)
--------------------------------	--

Analog composite input:	BNC×2, loop-through, 75Ω on/off
Reference input:	Analog composite BNC×2, loop-through, 75Ω on/off

Serial digital component input (option):	Complies with SMPTE 259M-C standard, BNC×2, active through
---	---

(Video output connector)

Analog component output:	BNC×3 (Y, Pb, Pr) Y; 1.0 Vp-p, 75Ω Pb, Pr; 0.486/0.7 Vp-p switchable, 75Ω (75% color bar, 7.5% setup)
---------------------------------	--

Analog composite output:	BNC×3 Video1/video2/video3 (superimpose on/off)
---------------------------------	--

Serial digital component output (option):	Complies with SMPTE 259M-C standard, BNC×3
--	---

(Video signals adjustment)

Composite video input signal:	±3 dB
Video output gain:	±3 dB
Video output chroma gain:	±3 dB
Video output hue:	±30°
Video output setup:	±15 IRE
Video output sync phase:	±15 μsec
Video output SC phase:	±180°
Video output Y/C delay:	±300 nsec

AUDIO

(Digital audio)

Sampling frequencies:	48 kHz
Quantizing:	16 bits
Frequency response:	20 Hz to 20 kHz ±1 dB
Dynamic range:	Better than 90 dB (1 kHz, emphasis OFF, "A" weighted)

Distortion:	Less than 0.05% (1 kHz, emphasis OFF, standard level)
--------------------	---

Crosstalk:	Less than -80 dB (1 kHz, between 2 channels)
-------------------	--

Wow & flutter:	Below measurable limit
---------------------------	------------------------

Headroom:	20 dB
Emphasis:	T1=50 μsec/T2=15 μsec (on/off selectable)

(Cue track)

Frequency response:	300 Hz to 6 kHz ±3 dB
----------------------------	-----------------------

(Audio input connector)

Analog input (CH1/CH2):	XLR×2, 600Ω/high impedance selectable, +4/0/-20 dBu
--------------------------------	---

Digital input (CH1/CH2):	XLR×1, AES/EBU format
Serial digital input (option):	Complies with SMPTE 259M-C, 272M standard (BNC, 75Ω)

Cue track input:	XLR×1, 600Ω/high impedance selectable, +4/0/-20/-60 dBu
-------------------------	---

(Audio output connector)

Analog output (CH1/CH2):	XLR×2, low impedance, +4/0/-20 dBu
---------------------------------	------------------------------------

Digital output (CH1/CH2):	XLR×1, AES/EBU format
Serial digital output (option):	Complies with SMPTE 259M-C, 272M standard (BNC, 75Ω)

Cue track output:	XLR×1, low impedance, +4/0/-20 dBu
--------------------------	------------------------------------

Monitor output:	XLR×2, low impedance, +4/0/-20 dBu
------------------------	------------------------------------

Headphones:	Variable level, mini-jack, 8Ω
--------------------	-------------------------------

Other input/output connector

Time code input:	XLR×1, 0.5 to 8 Vp-p
Time code output:	XLR×1, 2.0 Vp-p
RS-422A input/output:	D-sub 9-pin, RS-422A interface
RS-422A output:	D-sub 9-pin, RS-422A interface
RS-232C:	D-sub 25-pin, RS-232C interface
Parallel input/output:	D-sub 25-pin
Encoder remote:	D-sub 15-pin

Weight and dimensions shown are approximately. Specifications are subject to change without notice.

IMPORTANT

"Unauthorized recording of copyrighted television programs, video tapes and other materials may infringe the right of copyright owners and be contrary to copyright laws."

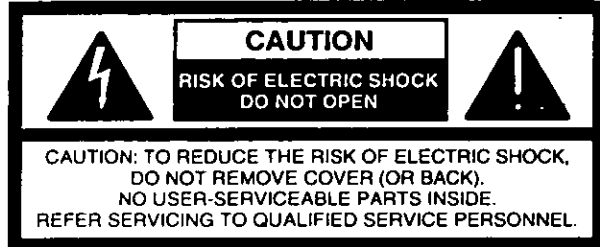

The lightning flash with arrowhead symbol, within an equilateral triangle, is intended to alert the user to the presence of uninsulated "dangerous voltage" within the product's enclosure that may be of sufficient magnitude to constitute a risk of electric shock to persons.



The exclamation point within an equilateral triangle is intended to alert the user to the presence of important operating and maintenance (servicing) instructions in the literature accompanying the appliance.

CAUTION:

To reduce the risk of fire or shock hazard and annoying interference, use the recommended accessories only.

WARNING:

TO REDUCE THE RISK OF FIRE OR SHOCK HAZARD, DO NOT EXPOSE THIS EQUIPMENT TO RAIN OR MOISTURE.

CAUTION:

TO REDUCE THE RISK OF FIRE OR SHOCK HAZARD, REFER MOUNTING OF THE OPTIONAL BOARD TO AUTHORIZED SERVICE PERSONNEL.

FCC Note:

This device complies with Part 15 of the FCC Rules. To assure continued compliance follow the attached installation instructions and do not make any unauthorized modifications.

This equipment has been tested and found to comply with the limits for a Class A digital device, pursuant to Part 15 of the FCC Rules. These limits are designed to provide reasonable protection against harmful interference when the equipment is operated in a commercial environment. This equipment generates, uses, and can radiate radio frequency energy and, if not installed and used in accordance with the instruction manual, may cause harmful interference to radio communications. Operation of this equipment in a residential area is likely to cause harmful interference in which case the user will be required to correct the interference at his own expense.

 is the safety information.

- Do not insert fingers or any objects into the video cassette holder.
- Avoid operating or leaving the unit near strong magnetic fields. Be especially careful of large audio speakers.
- Avoid operating or storing the unit in an excessively hot, cold, or damp environment as this may result in damage both to the recorder and to the tape.
- Do not spray any cleaner or wax directly on the unit.
- If the unit is not going to be used for a length of time, protect it from dirt and dust.
- Do not leave a cassette in the recorder when not in use.
- Do not block the ventilation slots of the unit.
- Use this unit horizontally and do not place anything on the top panel.
- Cassette tape can be used only for one-side, one direction recording. Two-way or two-track recordings cannot be made.
- Cassette tape can be used for either Color or Black & White recording.
- Do not attempt to disassemble the recorder. There are no user serviceable parts inside.
- If any liquid spills inside the recorder, have the recorder examined for possible damage.
- Refer any needed servicing to authorized service personnel.

Specifications

GENERAL

Power supply:	AC 220 – 240 V, 50 – 60 Hz
Power consumption:	210 W

Operating ambient temperature:	5°C to 40°C (41°F to 104°F)
Operating ambient humidity:	10% to 90% (no condensation)
Weight:	16.8 kg
Dimensions (W × H × D):	424 × 175 × 415 mm
Recording format:	DVCPRO format
Recording tracks:	Digital video Time code; Recorded in sub-code area Digital audio; 2 channels Cue signal; 1 track Control (CTL); 1 track
Tape speed:	33.854 mm/sec
Tape:	1/4-inch thin magnetic layer metal tape
Editing accuracy:	±0 frame (using time code)
Tape timer accuracy:	±1 frame (using continuous CTL signal)
Servo lock time:	Less than 0.5 sec. (colour framing/ standby ON)

VIDEO

(Digital video)

Sampling frequencies:	Y; 13.5 MHz/Pb, Pr; 3.375 MHz
Quantizing:	8 bits
Error correction:	Reed-Solomon product code

(Digital IN/analogue component OUT)

Video bandwidth:	Y; 25 Hz to 5.5 MHz (±0.5 dB) 5.75 MHz (-2 dB) Pb, Pr; 25 Hz to 1.3 MHz (±1 dB) 1.5 MHz (-5 dB) typ.
S/N ratio:	Better than 60 dB
K factor:	Less than 1%

(Analogue component IN/component OUT)

Video bandwidth:	Y; 25 Hz to 5.5 MHz (±1 dB) 5.75 MHz (-3 dB) Pb, Pr; 25 Hz to 1.3 MHz (±1 dB) 1.5 MHz (-6 dB) typ.
S/N ratio:	Better than 55 dB
K factor:	Less than 1%

(Analogue composite IN/composite OUT)

Video bandwidth:	Y; 25 Hz to 5.5 MHz (±1 dB) typ.
DG:	Less than 4%
DP:	Less than 3°
Y/C delay:	Better than 20 nsec
K factor:	Less than 2.5%

(Video input connector)

Analogue component input:	BNC×3 (Y, Pb, Pr) Y; 1.0 Vp-p, 75Ω Pb, Pr; 0.7 Vp-p, 75Ω (100% colour bar)
Analogue composite input:	BNC×2, loop-through, 75Ω on/off
Reference input:	Analogue composite BNC×2, loop-through, 75Ω on/off
Serial digital component input (option):	Complies with EBU Tech. 3267-E standard, BNC×2, active through

(Video output connector)

Analogue component output:	BNC×3 (Y, Pb, Pr) Y; 1.0 Vp-p, 75Ω Pb, Pr; 0.7 Vp-p, 75Ω (100% colour bar)
Analogue composite output:	BNC×3 Video1/video2/video3 (superimpose on/off)
Serial digital component output (option):	Complies with EBU Tech. 3267-E standard, BNC×3

(Video signals adjustment)

Composite video input signal:	±3 dB
Video output gain:	±3 dB
Video output chroma gain:	±3 dB
Video output chroma phase:	±30°
Video output black level:	±100 mV
Video output sync phase:	±15 μsec
Video output SC phase:	±180°
Video output Y/C delay:	±300 nsec

AUDIO

(Digital audio)

Sampling frequencies:	48 kHz
Quantizing:	16 bits
Frequency response:	20 Hz to 20 kHz ±1 dB Better than 90 dB (1 kHz, emphasis OFF, "A" weighted)
Dynamic range:	Better than 90 dB (1 kHz, emphasis OFF, standard level)
Distortion:	Less than 0.05% (1 kHz, emphasis OFF, standard level)
Crosstalk:	Less than -80 dB (1 kHz, between 2 channels)
Wow & flutter:	Below measurable limit
Headroom:	18 dB
Emphasis:	T1=50 μsec/T2=15 μsec (on/off selectable)

(Cue track)

Frequency response:	300 Hz to 6 kHz ±3 dB
----------------------------	-----------------------

(Audio input connector)

Analogue input (CH1/CH2):	XLR×2, 600Ω/high impedance selectable, +4/0/-20 dBu
Digital input (CH1/CH2):	XLR×1, AES/EBU format
Serial digital input (option):	Complies with EBU Tech. 3267-E standard (BNC, 75Ω)
Cue track input:	XLR×1, 600Ω/high impedance selectable, +4/0/-20/-60 dBu

(Audio output connector)

Analogue output (CH1/CH2):	XLR×2, low impedance, +4/0/-20 dBu
Digital output (CH1/CH2):	XLR×1, AES/EBU format
Serial digital output (option):	Complies with EBU Tech. 3267-E standard (BNC, 75Ω)
Cue track output:	XLR×1, low impedance, +4/0/-20 dBu
Monitor output:	XLR×2, low impedance, +4/0/-20 dBu
Headphones:	Variable level, mini-jack, 8Ω

Other input/output connector

Time code input:	XLR×1, 0.5 to 8 Vp-p
Time code output:	XLR×1, 2.0 Vp-p
RS-422A input/output:	D-sub 9-pin, RS-422A interface
RS-422A output:	D-sub 9-pin, RS-422A interface
RS-232C:	D-sub 25-pin, RS-232C interface
Parallel input/output:	D-sub 25-pin
Encoder remote:	D-sub 15-pin

Weight and dimensions shown are approximately. Specifications are subject to change without notice.

IMPORTANT

"Unauthorized recording of copyrighted television programmes, video tapes and other materials may infringe the right of copyright owners and be contrary to copyright laws."

■ **THIS APPARATUS MUST BE EARTHED**

To ensure safe operation the three-pin plug must be inserted only into a standard three-pin power point which is effectively earthed through the normal house-hold wiring.

Extension cords used with the equipment must be three-core and be correctly wired to provide connection to earth. Wrongly wired extension cords are a major cause of fatalities.

The fact that the equipment operates satisfactorily does not imply that the power point is earthed and that the installation is completely safe. For your safety, if in any doubt about the effective earthing of the power point, consult a qualified electrician.

■ **DO NOT REMOVE PANEL COVER BY UN-SCREWING**

To reduce the risk of electric shock, do not remove cover. No user serviceable parts inside. And do not insert fingers or any other objects into the video cassette holder.

CAUTION:

Do not install or place this unit in a bookcase, built in cabinet or in another confined space in order to keep well ventilated condition. Ensure that curtains and any other materials do not obstruct the ventilation condition to prevent risk of electric shock or fire hazard due to overheating.

WARNING:

TO REDUCE THE RISK OF FIRE OR SHOCK HAZARD, DO NOT EXPOSE THIS EQUIPMENT TO RAIN OR MOISTURE.

CAUTION:

TO REDUCE THE RISK OF FIRE OR SHOCK HAZARD, AND ANNOYING INTERFERENCE, USE THE RECOMMENDED ACCESSOIRES ONLY.

CAUTION:

TO REDUCE THE RISK OF FIRE OR SHOCK HAZARD, REFER MOUNTING OF THE OPTIONAL BOARD TO QUALIFIED SERVICE PERSONNEL.

Operating precaution

Operation near any appliance which generates strong magnetic fields may give rise to noise in the video and audio signals. If this should be the case, deal with the situation by, for instance, moving the source of the magnetic fields away from the unit before operation.

 is the safety information.

Attention/Attentie

- This apparatus contains a lithium battery for memory back-up.
- For the removal of the battery at the moment of the disposal at the end of the service life please consult your dealer.
- Do not throw away the battery. Instead, hand it in as hazardous waste.
- Dit apparaat bevat een lithiumbatterij voor memory back-up.
- Raadpleeg uw leverancier over de verwijdering van de batterij op het moment dat u het apparaat bij einde levensduur afdankt.
- Gooi de batterij niet weg, maar lever hem in als KCA.

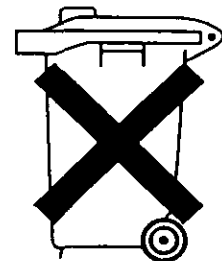

SAFETY PRECAUTIONS

GENERAL GUIDELINES

1. When servicing, observe the original lead dress. If a short circuit is found, replace all parts which have been overheated or damaged by the short circuit.
2. After servicing, see to it that all the protective devices such as insulation barriers, insulation papers shields are properly installed.
3. After servicing, make the following leakage current checks to prevent the customer from being exposed to shock hazards.

LEAKAGE CURRENT COLD CHECK

1. Unplug the AC cord and connect a jumper between the two prongs on the plug.
2. Measure the resistance value, with an ohm meter, between the jumpered AC plug and each exposed metallic cabinet part on the equipment such as screwheads, connectors, control shafts, etc. When the exposed metallic part has a return path to the chassis, the reading should be between $1M\Omega$ and $5.2M\Omega$.

When the exposed metal does not have a return path to the chassis, the reading must be ∞ .

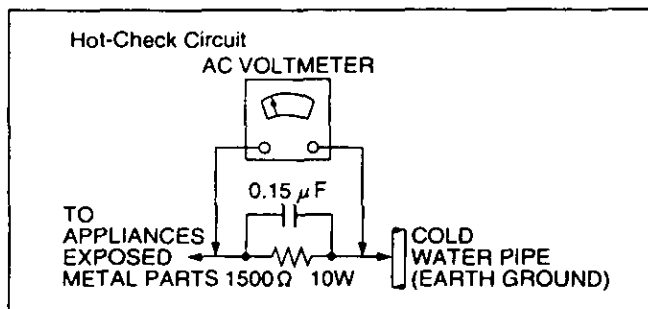

Figure 1

LEAKAGE CURRENT HOT CHECK (See Figure 1)

1. Plug the AC cord directly into the AC outlet. Do not use an isolation transformer for this check.
2. Connect a $1.5k\Omega$, $10W$ resistor, in parallel with a $0.15\mu F$ capacitor, between each exposed metallic part on the set and a good earth ground such as a water pipe, as shown in Figure 1.
3. Use an AC voltmeter, with 1000 ohms/volt or more sensitivity, to measure the potential across the resistor.
4. Check each exposed metallic part, and measure the voltage at each point.
5. Reverse the AC plug in the AC outlet repeat each of the above measurements.
6. The potential at any point should not exceed 0.75 volts RMS. A leakage current tester (Simpson Model 229 equivalent) may be used to make the hot checks, leakage current must not exceed 1/2 milliamp. In case a measurement is outside of the limits specified, there is a possibility of a shock hazard, and the equipment should be repaired and rechecked before it is returned to the customer.

ELECTROSTATICALLY SENSITIVE (ES) DEVICES

Some semiconductor (solid state) devices can be damaged easily by static electricity. Such components commonly are called Electrostatically sensitive (ES) Devices. Examples of typical ES devices are integrated circuits and some field-effect transistors and semiconductor "chip" components. The following techniques should be used to help reduce the incidence of component damage caused by static electricity.

1. Immediately before handling any semiconductor component or semiconductor-equipped assembly, drain off any electrostatic charge on your body by touching a known earth ground. Alternatively, obtain and wear a commercially available discharging wrist strap device, which should be removed for potential shock reasons prior to applying power to the unit under test.
2. After removing an electrical assembly equipped with ES devices, place the assembly on a conductive surface such as aluminum foil, to prevent electrostatic charge buildup or exposure of the assembly.
3. Use only a grounded tip soldering iron to solder or unsolder ES devices.
4. Use only an anti-static solder removal device classified as "anti-static" can generate electrical charges sufficient to damage ES devices.
5. Do not use freon-propelled chemicals. These can generate electrical charges sufficient to damage ES devices.
6. Do not remove a replacement ES device from its protective package until immediately before you are ready to install it. (most replacement ES devices are packaged with leads electrically shorted together by conductive foam, aluminum foil or comparable conductive material).
7. Immediately before removing the protective material from the leads of a replacement ES device, touch the protective material to the chassis or circuit assembly into which the device will be installed.
CAUTION: Be sure no power is applied to the chassis or circuit, and observe all other safety precautions.
8. Minimize bodily motions when handling unpackaged replacement ES devices. (Otherwise harmless motion such as the brushing together of your clothes fabric or the lifting of your foot from a carpeted floor can generate static electricity sufficient to damage an ES device).

X-RADIATION

WARNING

1. The potential source of X-Radiation in EVF sets is the High Voltage section and the picture tube.
2. When using a picture tube test jig for service, ensure that jig is capable of handling 10kV without causing X-Radiation.

NOTE: It is important to use an accurate periodically calibrated high voltage meter.

3. Measure the High Voltage. The meter (electric type) reading should indicate $2.5kV, \pm 0.15kV$. If the meter indication is out of tolerance, immediate service and correction is required to prevent the possibility of premature component failure. To prevent an X-Radiation possibility, it is essential to use the specified picture tube.

General and Features

This unit is a digital video cassette recorder which uses 1/4-inch tapes. It incorporates digital compression technology so that the deterioration in picture quality and sound quality resulting from dubbing is significantly minimized compared with existing analog systems. Furthermore, since it has a compact 4U size and light weight, the unit can be carried around or mounted in a 19-inch rack with ease. The settings for the unit's setup can be performed interactively while viewing the screen menus on the TV monitor, and editing functions include both assemble and insert editing.

Features

Compact size and light weight

This is a 4U size digital VTR. It can be mounted in a 19-inch rack with ease using the optional rack-mounting adaptors (AJ-MA75P).

Up to 184 minutes of recording

Two sizes of cassette tapes can be used with this unit: M cassette (max. 66 minutes) and L cassette (max. 184 minutes). The width of the tapes measures 1/4 inch to achieve a compact design.

Compatibility with consumer products

Consumer cassette tapes shot with digital cameras available on the consumer market can be played back on this unit using the optional cassette adaptor (AJ-CS750P).

<Notes>

- Slow motion playback is not possible with consumer cassette tapes.
- Consumer cassette tapes recorded in LP mode cannot be played back.

Digital slow motion/dial jog

The slow-motion playback images can be reproduced clearly at any of the speeds given below using commands from the external controller or other such device: $-0.43/-0.3/-0.2/-0.1/-0.03/0/+0.03/+0.1/+0.2/+0.3/+0.5/+0.75$.

<Note>

Some noise may occur when the slow motion speed is changed.

Digital audio output in slow-motion/jog mode

This enables smooth playback of sound even in the slow-motion or jog mode, making it easier to use sound to search for edit points and determine their positions.

Dial shuttle

Shuttle operations enable the tape to be played back with color images at a speed of up to 60 times normal tape speed in either the forward or reverse direction.

Internal audio memory with 20-second capacity

Sound can now be recorded as pictures are played back without any time lag between the sound and picture (a process known as "voice-over"). Audio cross channel editing is enabled by using the unit in combination with an external sound mixer.

Audio memory unit (AJ-YA752) supported

Voice-over extending up to 34 minutes and 30 seconds (5 min. 46 sec. standard) is enabled by connecting the AJ-YA752 unit (optional accessory).

Features

(continued)

Recording and playing back V blanking data

In addition to closed caption and VITC, up to 28 lines of the character data per frame in the V blanking period can be recorded and played back.

<Note>

There is some limitation to the number of lines in which signals can be recorded.

Time codes

This unit comes with a built-in time code generator (TCG)/time code reader (TCR). In addition to the internal time code, an external code input or input signal VITC can be recorded in the machine as the LTC time code.

Multi-function input/output interfaces

- **Analog input/output**

Component (Y, Pb, Pr) and composite signal input and output connectors are provided.

- **Serial digital input/output**

Digital component interfacing complying with the EBU Tech. 3267-E serial digital signal standard is possible when the optional component serial interface board (AJ-YA750P) is used. Transfer using SDTI is enabled by the AJ-YAC850P SDTI/SDI board (option). (SMPTE 305M)

- **AES/EBU audio input/output**

Digital audio input and output connectors are provided.

- **9-pin (RS-422A)/(RS-232C) remote**

In addition to the standard 9-pin serial (RS-422A) connector, RS-232C and 25-pin parallel connectors are also featured.

The RS-422A connector enables another VTR to be operated in parallel with the unit if a looping connection is used for the two units.

2-channel high-sound-quality digital audio

Sound can be edited separately for two channels while channel mixing capabilities are also available. One channel is provided for the analog cue track.

Automatic editing functions

Assembly and insert editing can be performed.

Menu-driven setup

The setup settings, which are conducted prior to operating the unit, are performed while viewing the setup menus either on the unit's display or a TV monitor.

Controls and their functions

Front panel

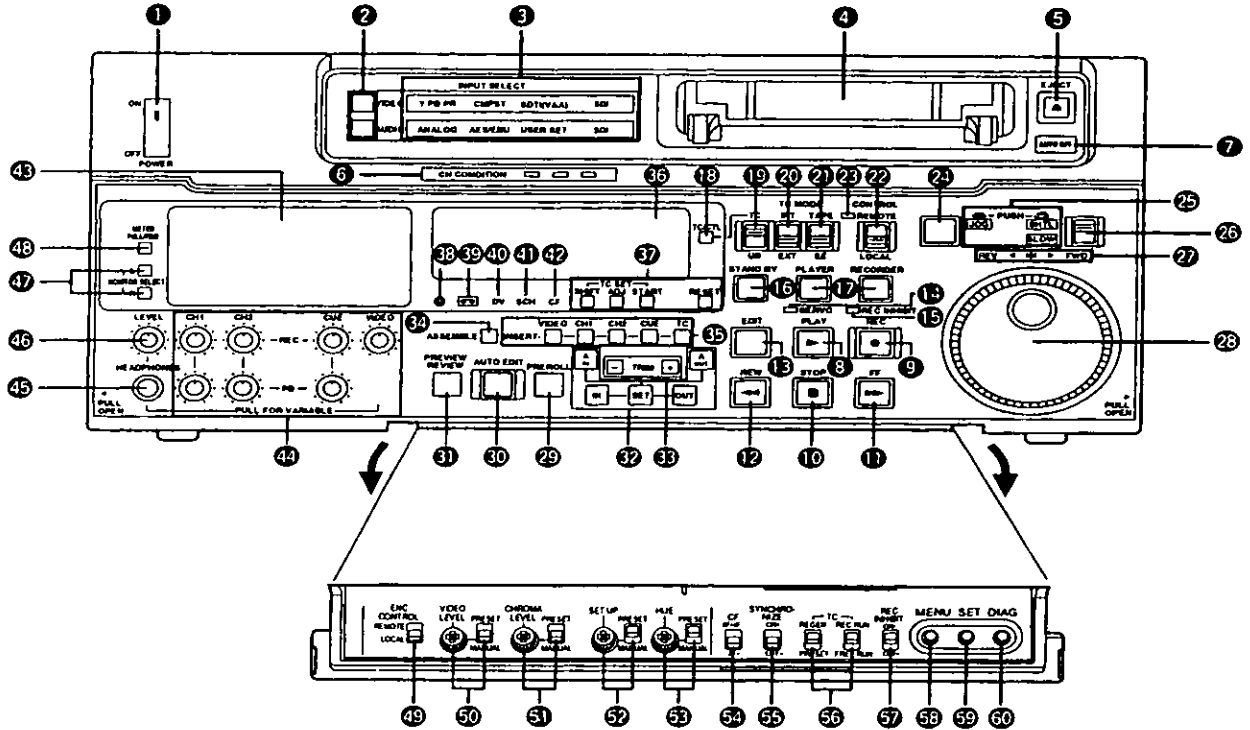

<Front Panel Top Section>

① POWER switch

When the ON side is pressed, the power is switched on, and the audio level and video level meters, counter display and INPUT SELECT display light up.

② INPUT SELECT switches

These are used to select the video and audio input signals.

<Video>

Each time the VIDEO button is pressed, the input video signal selection is switched in the order of Y P_B P_R, COMPOSITE, SDTI (V&A), SDI and back to Y P_B P_R. If SDTI (V&A) is selected, both the video and audio signals will be input from SDTI.

<Audio>

Each time the AUDIO button is pressed, the input audio signal selection is switched in the order of ANALOG, AES/EBU, USER SET, SDI and back to ANALOG.

USER SET is a function for selecting two different input signals to be recorded on PCM audio signal CH1 and CH2, and it is used in tandem with the setup menu.

For instance, if USER SET is selected by INPUT SELECT and CH1=ANALOG, and CH2=DIGI are selected on the setup menu No. 710 (CH1 IN SEL), No. 711 (CH2 IN SEL) and No. 712 (DIGI IN SEL), the analog input signal and AES/EBU digital signal will be respectively recorded on channels 1 and 2 of the PCM audio signals recorded on the tape. However, when SDTI has been selected for the video input, SDTI input will be forcibly established for the audio input as well.

<Front Panel Top Section>

③ INPUT SELECT display

The characters corresponding to the selected input signal light. When, with the exception of analog signals, the selected input signals are not available, the display flashes to alert the user.

<Video>

Y PB PR: Analog component video signal

CMPST: Analog composite video signal

SDTI (V&A): Compressed data, serial and digital video and audio signals (option)

SDI: Serial digital video signal (EBU Tech. 3267-E) (option)

When BB has been selected as the setup menu No. 601 (INT BB SIG) setting, the entire display area will light up.

<Audio>

ANALOG: Analog audio signal

AES/EBU: Digital audio signal

USER SET: Selection of audio signal to be recorded

SDI: Serial digital audio signal (EBU Tech. 3267-E) (option)

When ON has been selected as the setup menu No. 722 (INT SG) setting, the entire display area will light up.

④ Cassette insertion slot

The M cassette, L cassette and consumer cassette (S cassette) with adaptor are inserted into this slot.

Consumer cassettes can be played back only.

⑤ EJECT button

When this is pressed, the tape is unloaded and several seconds later the cassette is automatically ejected. When the counter display indicates "CTL", the display is reset.

The lamp lights when the eject command is received.

⑥ Channel condition lamps

One of these lamps lights in accordance with the error rate status. (Green→amber→red)

Green: This lights when the error rates for the video and audio playback signals are both acceptable.

Amber: This lights when the error rate for the video or audio playback signals has deteriorated.

Red: The playback picture will remain normal even when this lamp lights.

This lights when the video or audio signals are subject to rectification or interpolation.

⑦ AUTO OFF lamp

This lights when trouble has arisen in the deck's operation.

Controls and their functions (continued)

<Front Panel Center Section>

8 PLAY button

Playback commences when this button is pressed.

Recording commences when the button is pressed together with the REC button; manual editing commences when it is pressed together with the EDIT button during playback.

Pressing only the PLAY button during manual editing will cut out the editing and establish the playback mode.

9 REC button

Recording commences when this button is pressed together with the PLAY button.

When it is pressed during playback, search, fast forward or rewind, EE mode images and audio signals can be monitored for as long as it is kept depressed.

When it is pressed in the stop mode, EE mode images and sound can be monitored.

When the STOP button is pressed, the original picture and sound are restored.

10 STOP button

When this is pressed, the tape stops traveling, and if the TAPE/EE selector switch is at TAPE, still pictures can be monitored.

The drum continues to rotate even in the stop mode, and the tape remains in close contact with the drum.

If the stop mode continues for more than a certain period of time, the unit automatically switches to the standby OFF mode in order to protect the tape.

The stop mode is established immediately after a cassette has been inserted into the unit.

11 FF button*

The tape is fast forwarded when this is pressed.

12 REW button*

The tape is rewound when this is pressed.

13 EDIT button

For manual editing, press both this button and the PLAY button together during playback.

When the button is pressed in the stop mode, the input mode signals selected by the ASSEMBLE or INSERT button can be monitored in the EE mode.

The original picture and sound are restored when the STOP button is pressed.

When the button is pressed during playback, search, fast forward or rewind, the input signals of the mode selected by the ASSEMBLE or INSERT button can be monitored in the EE mode for as long as the button is held down.

14 SERVO lamp

This lights when the drum servo and capstan servo have locked.

15 REC INHIBIT lamp

This lights when the REC INHIBIT switch in the front panel bottom section is at ON or when the accidental erasure prevention mode has been set for the cassette.

In this state, neither recording nor editing is possible.

* The FF/REW speed can be selected on the setup menu No. 102 (FF. REW MAX), and it is set to the same speed.

<Front Panel Center Section>

⑯ STANDBY button

When this is pressed, the same tension as in the regular stop mode is applied to the tape, and while the head drum continues to rotate, the button's lamp lights to indicate that the standby ON mode is established.

In the standby OFF mode, the half-loading mode is established.

When this button is pressed in the stop mode, the standby OFF mode is established, the half-loading mode is established. The lamp in the button now goes off. When the unit remains in the stop mode for longer than a predetermined period, the standby OFF mode is automatically established in order to protect the tape.

When this button or the STOP button is pressed in the standby OFF mode, the standby ON mode is established.

When a button other than the STOP button is pressed, the mode corresponding to the button pressed is established.

On-screen settings are available for the transfer time to the standby OFF mode.

⑰ PLAYER/RECORDER buttons

These buttons are operated when editing operations are conducted using the unit as the recorder and a VTR equipped with an RS-422A serial interface remote control connector (9 pins). Neither button functions when the unit is used on its own.

PLAYER button: When this button is pressed, its lamp lights, and the player connected to the unit can be operated by remote control. The unit's editing and tape transport buttons now control the player's functions.

RECORDER button: When this button is pressed, its lamp lights, and the editing and tape transport buttons control the recorder's (= the unit's) functions.

⑱ TC/CTL switch

By pressing this switch, what appears on the counter display is changed between TC and CTL.

When TC is selected, either the TC or UB value is displayed depending on the position selected by the TC/UB switch.

⑲ TC/UB switch

This selector switch determines whether the value of TC or UB appears on the counter display when the TC/CTL switch has been set to TC.

⑳ INT/EXT switch

INT: For using the built-in time code generator.

EXT: For using the time external code which is input from the time code input connector or the video signal VITC. The selection is set at the setup menu No. 505 (EXT TC SEL).

㉑ TAPE/EE switch

<In the stop mode>

TAPE: For outputting the signals played back from the tape.

EE: For outputting the input signals selected by the INPUT SELECT switch.

Select NORMAL or THRU as the setup menu No. 116 (EE MODE SEL) setting. In either case, use the switch for monitoring purposes.

<In the editing*/recording mode>

TAPE: For outputting the simultaneous playback signals.

EE: For outputting the input signals selected by the INPUT SELECT switch.

* The SETUP menu No. 308 (CONFI EDIT) setting is required.

Controls and their functions (continued)

<Front Panel Center Section>

② REMOTE/LOCAL switch

This switch is set when the unit is to be controlled from an external source using the REMOTE connector, RS-232C connector or parallel connector.

REMOTE: Set to this position when controlling the unit by a device connected using the 9-pin REMOTE connector or RS-232C/parallel connector.

LOCAL: Set to this position when controlling the unit using the controls on its own operation panel.

③ REMOTE lamp

This lights when the REMOTE/LOCAL switch has been set to the REMOTE position.

④ Search button

This button is pressed to establish the search mode.

When the search dial is set to the shuttle mode and turned to a particular position, and this button is pressed, playback commences at the speed set by the search dial.

⑤ JOG/SHTL/SLOW lamps

These indicate the present status of the search dial and SHTL/SLOW switch.

JOG: This lights when the unit is in the JOG mode.

SHTL: This lights when the unit is in the SHTL mode.

SLOW: This lights when the unit is in the VAR (variable) mode.

⑥ SHTL/SLOW switch

This selector switch is set when the search dial is used for SHTL or SLOW applications.

⑦ REV/STILL/FWD lamps

One of these lamps lights depending on the operation of the search dial.

REV: This lights when the dial is turned counterclockwise and the tape travels in the REV direction provided that the lamp in the search button has lighted.

STILL: This lights in the JOG mode while the dial is kept stationary, and the tape stops traveling provided that the lamp in the search button has lighted.

It lights in the SHTL mode provided that the dial is at the STILL position.

FWD: This lights when the dial is turned clockwise, and the tape travels in the FWD direction provided that the lamp in the search button has lighted.

⑧ Search dial

This is used to search for the edit points.

Each time it is pressed, the mode is alternately set to shuttle or jog, and one of the JOG, SHTL and SLOW lamps lights. When the power has been turned on, the dial will not function until it has first returned to the STILL position.

Shuttle mode: When the dial is turned and stopped at a particular position while the SHTL/SLOW switch is at SHTL, the tape can be played back at the speed corresponding to the dial's rotary angle position. A still picture appears at the dial's center position.

When the dial is turned all the way counterclockwise with the SHTL/SLOW switch at SLOW, the tape speed is set to $-4\times$ normal speed, when it is set to the center position, a still picture is produced, and when it is turned all the way clockwise, the tape speed is set to $+4\times$ normal speed. The maximum speed for SLOW can be set using setup menus No. 317 (VAR FWD MAX) and No. 318 (VAR REV MAX).

Jog mode: The dial clickstops are cleared, and the tape is played back at the speed corresponding to the speed at which the dial is turned. The maximum speed can be selected using the setup menu No. 320 (JOG FWD MAX) and No. 321 (JOG REV MAX) settings.

<Front Panel Center Section>

②⑨ PREROLL button

This is used for feeding and cueing the tape for manual editing.

When it is pressed, the tape travels to the preroll point where it stops.

The preroll time can be set on the setup menu No. 000 (P-ROLL TIME).

When this button is pressed while the IN or OUT button is held down, the tape can be cued to the IN or OUT point entered.

When the AUTO ENTRY on the setup menu No. 311 is set to "ENA", IN point has been entered at the point where the PREROLL button is pressed even if the IN point has not been entered.

③⑩ AUTO EDIT button

Automatic editing is executed when this is pressed after an edit point has been entered.

When the AUTO EDIT button is pressed though the IN point has not been entered, automatic editing is executed using the point at which the button was pressed as the IN point.

③⑪ PREVIEW/REVIEW buttons

PREVIEW: When this is pressed after an edit point has been entered, the tape travels, editing is not performed, and the rehearsal can be activated on the screen connected to the recorder.

If it is pressed when the IN point has not been entered, the point at which the button was pressed is entered as the IN point, and preview is executed accordingly.

REVIEW: If this is pressed after a block has been edited, the now edited block can be played back and monitored on the screen connected to the recorder.

③⑫ IN (A IN)/SET/OUT (A OUT) buttons

When the SET button is pressed while the IN (A IN) or OUT (A OUT) button is held down, the IN or OUT point is entered.

The A IN and A OUT buttons are used to enter audio IN and OUT points which are different from the corresponding video points for audio split editing.

While an IN or OUT point is being entered, the lamp in the IN or OUT button corresponding to the point being entered lights.

When this button is pressed after a point has been entered, the IN or OUT point value appears on the counter display. When the IN or OUT button is pressed together with the RESET button, the IN or OUT point entry is cleared.

③⑬ TRIM buttons

These buttons are used to trim IN or OUT point finely.

When the "+" or "-" button is pressed while the IN or OUT button is held down, the entered edit point can be trimmed in 1-frame increments. When the "+" button is pressed, the tape is advanced by one frame; when the "-" button is pressed, it is rewound by one frame.

③⑭ ASSEMBLE button

This is pressed for assemble editing.

The button is self-illuminating, and it is set ON (lamp lights) when it is pressed once and OFF (lamp goes off) when it is pressed again.

③⑮ INSERT buttons

Press one of these five buttons to select the input signals to be edited during insert editing.

The buttons are self-illuminating, and they are set ON (lamp lights) when they are pressed once and OFF (lamp goes off) when they are pressed again.

③⑯ Counter display

This displays the TC and CTL count values, on-screen information and other messages.

Controls and their functions (continued)

<Front Panel Center Section>

① Time code buttons

These are used to set the TC or UB value.

SHIFT: When setting the TC or UB value, first press this button to stop the data running. Change the digit now flashing on the display.

Each time the button is pressed, the flashing moves to the right by one digit, and when it reaches the right-most digit, it returns to the left-most digit.

When it is kept depressed, the flashing moves consecutively.

ADJ: This is used to change the numeral of the digit now flashing on the display.

When the button is pressed once, the number is incremented by 1, and when it is kept depressed, the number is incremented consecutively.

START: This enters the data which has been changed by the SHIFT and ADJ buttons.

Also, Pressing this button when the TC or UB value are not set enables the TCG or UBG setting values to be confirmed.

RESET: When this button is pressed in the CTL mode, the display is reset to "00:00:00:00". In the CTL mode, the entered edit points are cleared.

In the TC/UB mode, the generator is reset when the button is pressed together with the SHIFT button.

② Warning lamp

This lights to warn the operator of a particular item.

③ Cassette insertion display lamp

This lights when a cassette has been inserted into the unit.

④ Consumer cassette insertion display lamp

This lights when a cassette recorded on a consumer DV device has been inserted.

⑤ SCH lamp

This lights when the SCH of the external sync signal is within a specific range.

⑥ CF lamp

This lights when the color framing is locked.

⑦ Level meters

These indicate the PCM audio signal CH1/CH2, CUE track signal and video signal levels.

The audio signal indicates the output signal levels.

The video signal indicates the input signal levels.

⑧ Input/output level controls*

These are used to adjust the recording and playback levels of the PCM audio signal CH1/CH2 and CUE track signals and the recording level of the composite video signals.

Each control located on the upper level is for adjusting the recording level, and each control located on the lower level is for adjusting the playback level.

These are "pull for variable" controls which means that they enable adjustment only when they have been pulled up. The signals levels are set to the unity value (preset value) when the controls have been pushed down.

⑨ Headphones jack

The sound being recorded, played back or edited can be monitored on stereo headphones when they are connected to this jack.

* The input levels are always fixed (at -18 dB) when "ON" has been selected as the setup menu No. 722 (INT SG) setting

<Front Panel Center Section>

④⑥ Volume control

This is used to adjust the headphones volume and the monitor output volume.

Whether the headphones output and monitor output volumes are to be linked or kept separate can be set on the setup menu No. 708 (MONI OUT). (Note that the headphones output volume is normally linked.)

When the volumes are kept separate, the monitor output is set to the unity value (preset value).

④⑦ MONITOR SELECT switches

These are used to select the audio signals output to the monitor L/R channels.

Each time the "L" button is pressed, the signals output to the monitor L channel are selected in turn in the following order: CH1, CH2, CUE and back to CH1.

Each time the "R" button is pressed, the signals output to the monitor R channel are selected in turn in the following order: CH1, CH2, CUE and back to CH1.

The L or R lamp on the level meter display lights to indicate which signal is now being selected. (When the unit is set to "AUTO 1" or "AUTO 2" in No. 713 (MONI CH SEL) on the setup menu, then the display will change according to the monitor output.)

④⑧ METER (FULL/FINE) selector switch

This switch is used to select the scale unit display mode for the audio level meters.

FULL mode: Standard scale units (ranging from $-\infty$ to 0 dB) are used.

FINE mode: The scale is divided up into 0.5 dB increments.

Controls and their functions (continued)

<Front Panel Bottom Section>

49 ENCODER CONTROL switch

This selects whether the adjustments to the video output signals are to be performed by the unit or by an external encoder/remote controller.

REMOTE: The adjustments to the video output signals are performed by the external encoder/remote controller.

LOCAL: The adjustments to the video output signals are performed by the unit.

50 VIDEO LEVEL control and switch

When the ENCODER CONTROL switch is at LOCAL, the video level can be adjusted.

When it is at PRESET, the video level is set to the unity value (0 dB).

When it is at MANUAL, the video level can be adjusted using this control.

51 CHROMA LEVEL control and switch

When the ENCODER CONTROL switch is at LOCAL, the chroma level can be adjusted.

When it is at PRESET, the chroma level is set to the unity value (0 dB). When it is at

MANUAL, the chroma level can be adjusted using this control.

52 SET UP control and switch (Composite output only variable.)

When the ENCODER CONTROL switch is at LOCAL, the setup level can be adjusted.

When it is at PRESET, the setup level is set to the unity value (0 IRE). When it is at

MANUAL, the setup level can be adjusted using this control.

53 HUE control and switch (Composite output only variable.)

When the ENCODER CONTROL switch is at LOCAL, the hue can be adjusted. When it is

at PRESET, the hue is set to the unity value (0°). When it is at MANUAL, the hue can be

adjusted using this control.

54 CF switch

This selects whether the playback framing is to be locked in 8/4-field increments or 2-field increments.

8F/4F: The framing is locked in 8/4-field increments.

2F: The framing is locked in 2-field increments.

Switching to 8F or 4F is enabled by the SETUP menu No. 107 (CAP.LOCK) setting.

55 SYNCHRONIZE switch

This selects whether to provide phase synchronization between two decks.

ON: Phase synchronization is provided. Error-less editing can be performed.

OFF: Phase synchronization is not provided. The edit point will be off by several frames, but editing can be performed quickly.

56 TC generator switch

REGEN: When the REGEN/PRESET switch is at REGEN, the internal time code generator is synchronized with the time code which the time code reader read from the tape. Whether to set TC or UB to REGEN can be selected at the setup menu No. 503 (TCG REGEN).

PRESET: When the REGEN/PRESET switch is at PRESET, presetting is enabled by the controls on the operation panel or by remote control.

REC RUN: The time code runs only during recording when the RUN MODE switch has been set to REC. The time code runs constantly when the REGEN/PRESET switch is set to REGEN.

FREE RUN: The time code runs regardless of the operation mode as long as the power is being supplied when the RUN MODE switch has been set to FREE.

<Front Panel Bottom Section>

⑦ REC INHIBIT switch

This selects whether to enable or inhibit the recording on the cassette tape.

ON: The recording on the cassette tape is inhibited.

The REC INHIBIT lamp on the front panel now lights.

OFF: The recording on the cassette tape is enabled provided that the cassette's accidental erasure prevention mechanism has been set to the recording enable position.

⑧ MENU button

When this is pressed, the setup menu appears on the TV monitor using VIDEO OUT 3 connector, and the setup menu No. appears on the display.

When it is pressed again, the setup menu setting mode is exited and the original operating mode is restored.

⑨ SET button

When this is pressed, the data which has been set on the setup menu is entered. After data entry, the setup menu setting mode is exited and the original operating mode is restored.

⑩ DIAG button

When this is pressed, VTR information is displayed. When it is pressed again, the original display is restored.

There are two types of VTR information: "HOURS METER" information and "WARNING" information. Switching between these types is enabled by pressing the search button.

Indicated on the "HOURS METER" screen are the power-on time, drum rotation time, tape travel time, loading count, etc.

Indicated on the "WARNING" screen are the warnings.

Controls and their functions (continued)

Connector area

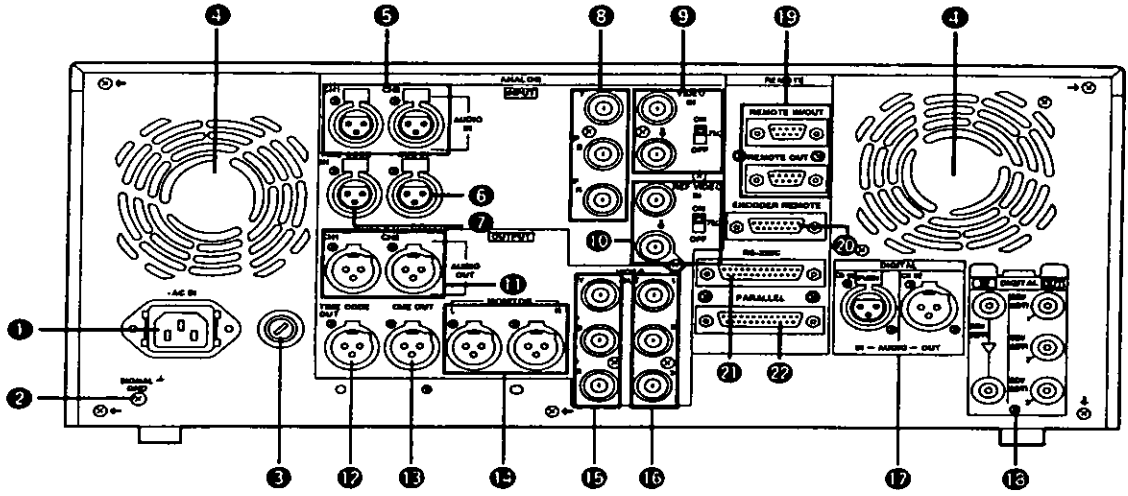

<Connector area>

① AC IN connector

This is for connecting the unit to the power outlet using the power cord provided.

② SIGNAL GND terminal

This terminal is connected to the signal unit which is connected to the unit in order to reduce noise. It is not connected to ground for safety purposes.

③ Fuse holder

This contains a fuse.

④ Fan motor

This is for cooling the unit.

The  lamp lights when trouble has caused the fan motor to stop. If the unit is still operated in the warning status, the temperature inside the deck will rise, and when it exceeds the safety temperature, all the unit's operations will be shut down.

⑤ ANALOG AUDIO IN connectors

These are the analog audio input connectors.

⑥ CUE IN connector

The analog signal to be recorded on the CUE track is supplied to this connector. The audio signals from a microphone can also be recorded by selecting the -60 dB input mode on the setup menu No. 702 (CUE IN LV).

⑦ TIME CODE IN connector

This is the connector for recording the external time code on the tape.

⑧ ANALOG COMPONENT VIDEO IN connector

The analog component video signal is supplied to this connector.

⑨ ANALOG COMPOSITE VIDEO IN connectors and 75Ω termination switch

The analog composite video signal is supplied to these two connectors which are connected in a loop-through configuration. When the termination is required, set the switch to ON.

⑩ REF VIDEO IN connectors and 75Ω termination switch

These are the input connectors for the reference video signals. When the termination is required, set the switch to ON.

⑪ ANALOG AUDIO OUT connectors

The analog audio signals are output from these connectors.

⑫ TIME CODE OUT connector

The playback time code is output from this connector during playback.

During recording, the time code generated by the internal time code generator is output.

⑬ CUE OUT connector

The analog signal recorded on the CUE track is output from this connector.

⑭ MONITOR OUT connector

During playback, the playback signals from the CUE track or PCM audio signal CH1/CH2 are output from this connector.

Controls and their functions (continued)

<Connector area>

⑮ ANALOG COMPONENT VIDEO OUT connector

The analog component video signal is output from this connector.

⑯ ANALOG COMPOSITE VIDEO OUT connectors

The analog composite video signals are output from these connectors.

The video signal with signals superimposed on it can be output from the VIDEO OUT3 connector.

The superimpose function can be set ON or OFF on the setup menu No. 006 (SUPER).

⑰ DIGITAL AUDIO IN/OUT connector

This I/O connector is for digital audio signals which comply with the AES/EBU standard.

**⑱ SERIAL DIGITAL COMPONENT AUDIO/VIDEO IN/OUT connector
(optional AJ-YA750P interface board required)**

This I/O connector is for digital component audio and video signals which comply with the EBU Tech. 3267-E standard.

The connectors are known by different names when the AJ-YAC850P SDTI/SDI board (option) is used. For further details, refer to the operating instructions of the AJ-YAC850P board.

⑲ Remote control connectors

The unit can be controlled from an external source by connecting the unit with another unit or an external controller.

There are two remote control connectors, one for IN/OUT uses and the other for OUT uses.

IN/OUT: For connection with an external controller.

For connection with deck-to-deck operation.

OUT: For connection with parallel running operations.

⑳ ENCODER REMOTE connector

The external encoder/controller is hooked up to this connector when the video output signal and other settings are to be adjusted from an external source.

㉑ RS-232C connector

㉒ PARALLEL REMOTE connector

This is used when operating the unit from an external source.

Connections when one unit is used

Set the CONTROL switch on the front panel to LOCAL.

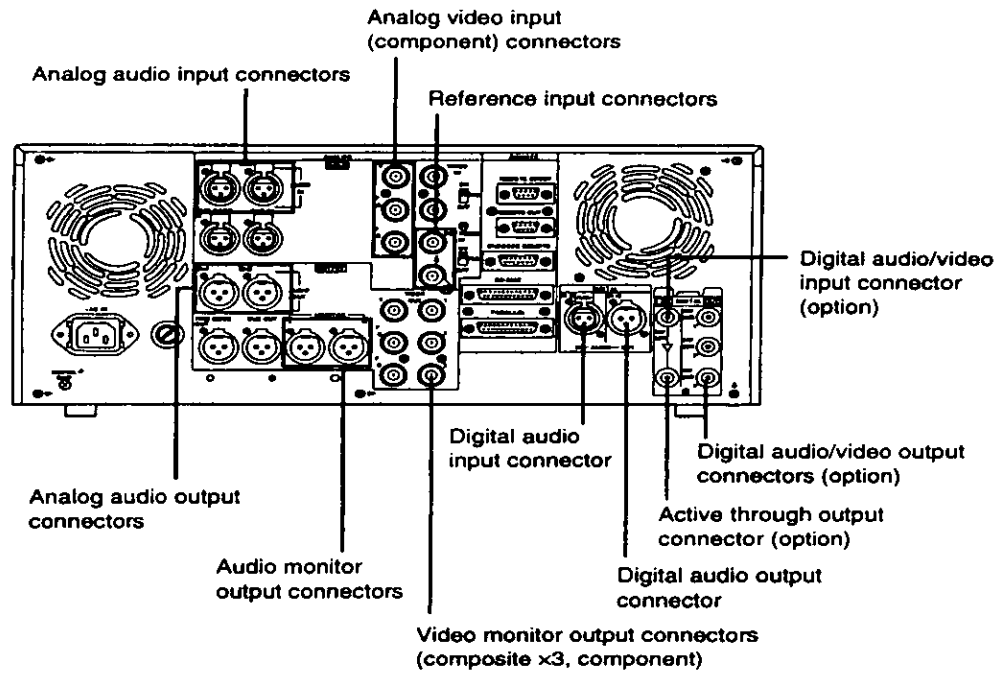

Connections when 2 units are used (deck to deck)

Source machine: • Set the CONTROL switch on the front panel to REMOTE.

Recorder: • Set the CONTROL switch on the front panel to LOCAL.

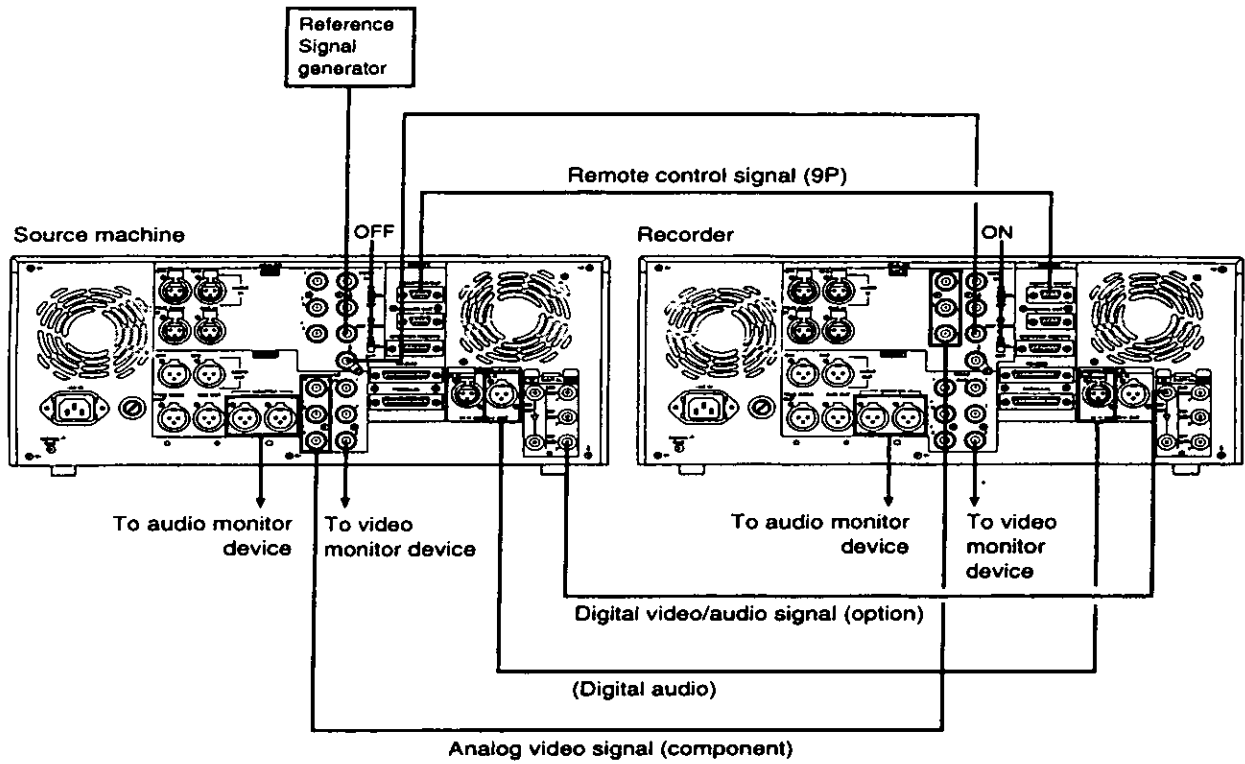

Connections with editing controller

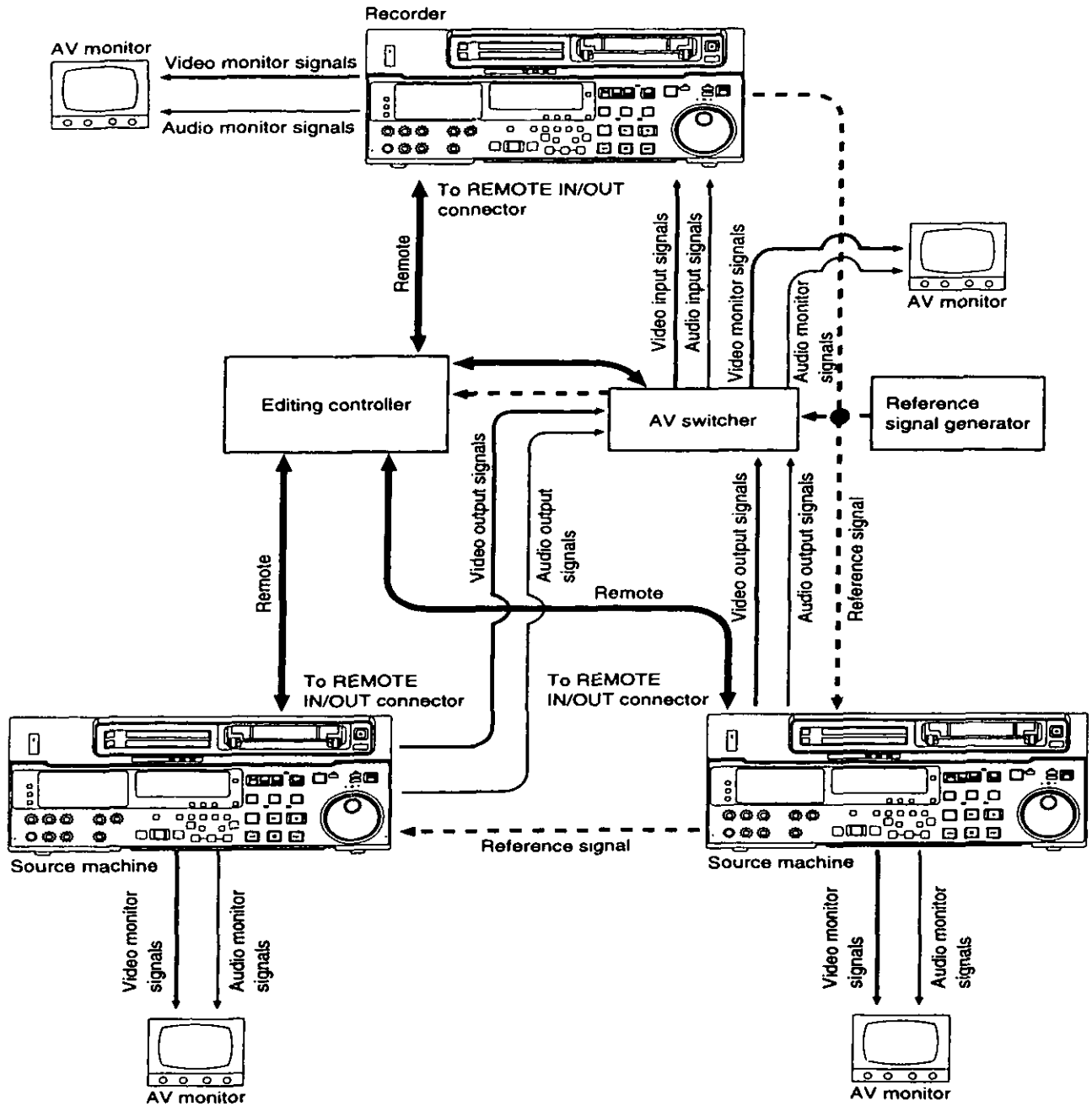

<Note>

When an editing controller made by CMX is used, support must be provided at the editing controller side.

Connections for adjusting video output (encoder output) signals

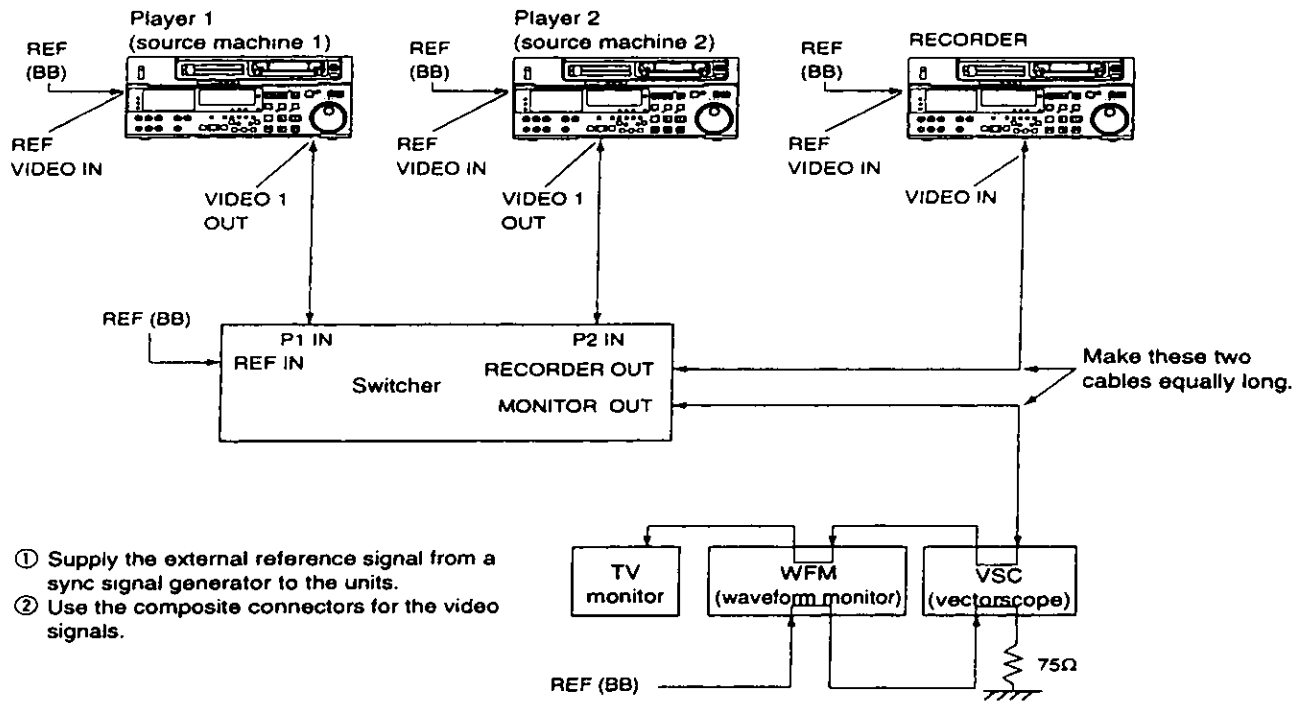

Tapes

Type	Description
Consumer cassette (S cassette)	Tape designed exclusively for the camcorders used by consumers in general. Only playback is possible using the optional cassette adaptor. However, please note that long-play cassette tapes (80-minute standard/120-minute LP mode) cannot be used. Use of Panasonic consumer DV cassette tapes is recommended. Note that inserting a cassette tape without using the cassette adaptor can damage the unit.
M cassette	Recording/playback tape with a maximum capacity of 66 minutes. (AJ-P12MP, AJ-P24MP, AJ-P33MP, AJ-P46MP, AJ-P66MP)
L cassette	Recording/playback tape with a maximum capacity of 184 minutes. (AJ-P34LP, AJ-P66LP, AJ-P94LP, AJ-P126LP, AJ-5P92LP)

Align the cassette with the center of the insertion slot and push it in gently. The cassette tape is loaded automatically.

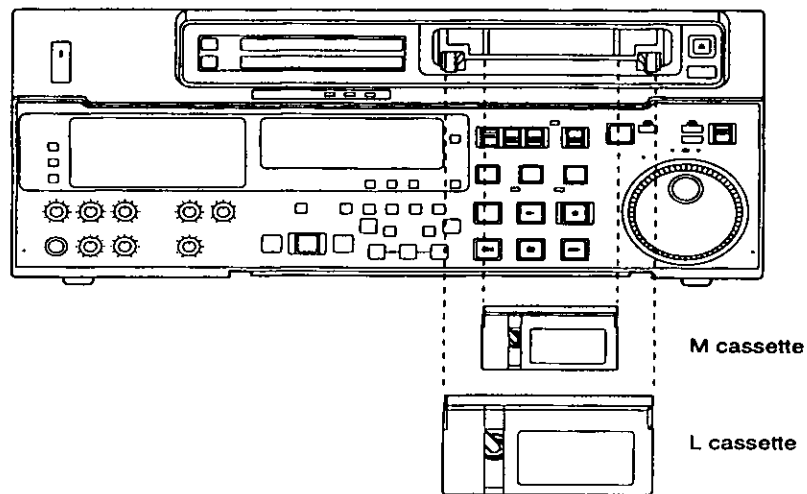

<Note>

For AJ-5P92LP cassette tapes recorded using the DVCPRO (25 Mbps) mode, use a VTR supporting DVCPRO (25 Mbps) 184 minute tapes.

<Cautions when playing back consumer DV tapes and DVCAM tapes>

- Consumer DV tapes and DVCAM tapes can be used for playback only.
- Consumer DV tapes which have been recorded in the LP mode cannot be played back.
- When materials which have been recorded on consumer DV tapes or DVCAM tapes are to be edited, record them onto a DVCPRO tape or tape of any other broadcasting VTR for use.
- Recordings cannot be made on consumer DV tapes and DVCAM tapes: this means that all functions related to recording, REC operation, editing selection and execution, TAPE/EE switching and other such operations are prohibited.
- The maximum transport speed for consumer DV tapes and DVCAM tapes is 32 times the normal tape speed.
- The maximum time for the STILL TIMER when consumer DV tapes or DVCAM tapes are used is set to 10 seconds, and the total STEP FWD time when the machine has been left standing in the STILL status is set to 1 minute.
- Slow-motion playback of consumer DV tapes and DVCAM tapes is not possible.
- In order to protect your tapes, it is recommended that repeated cue-up in the same location on a consumer DV tape or DVCAM tape be avoided as far as possible.
- Finally, check out the cautionary items for setup menu item No. 108 "FORMAT SEL".

Switching on the power/inserting the cassette

Before starting to operate the unit, check whether the equipment has been connected properly.

- 1** Turn on the power.
- 2** Check that the AUTO OFF lamp is off.
When condensation has formed or some other trouble has occurred, the AUTO OFF lamp lights, and all operations are disabled.
- 3** Insert the cassette tape.
Insert the tape at its proper position without force.
- 4** Check that the STOP lamp is on.
When the tape is inserted, the cylinder rotates automatically, the tape is loaded and the unit goes into the stop mode. The EJECT lamp goes off.

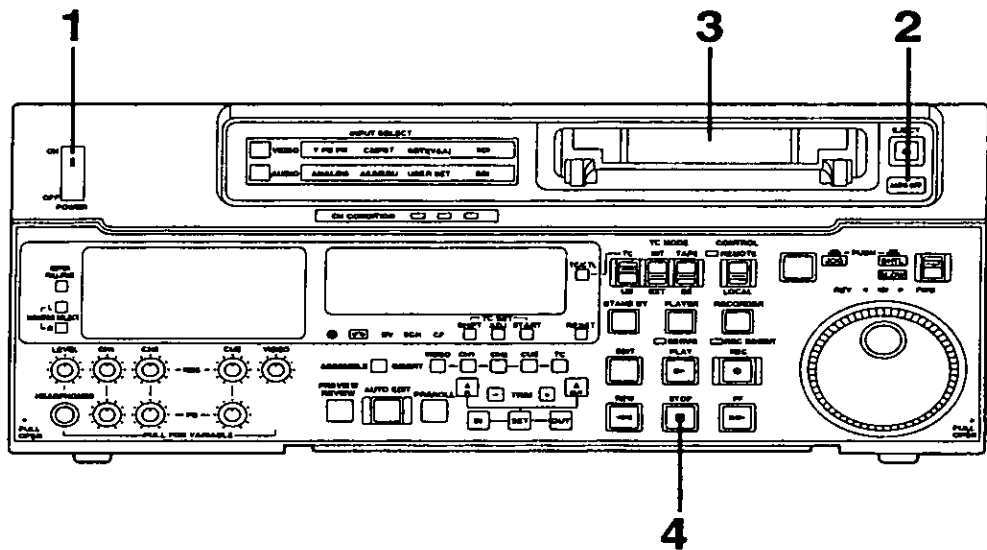

STOP/STAND BY mode

- 1** When the STOP button is pressed, the unit goes into the stop mode. The STOP lamp lights and the tape stops traveling.
 - In order to protect the tape, the unit goes into the standby OFF mode after the time set by setup menu No. 400 (STILL TIMER) has elapsed. When the STOP, REW, FF or PLAY button is pressed, the unit will go into the appropriate mode.
- 2** When the STAND BY button is pressed, the unit goes into the standby ON/OFF mode. When the button's lamp is lighted, the unit is in the standby ON mode. When the button is pressed during the stop mode, the unit goes into the standby OFF mode and half-loading mode and the lamp goes off. When the button is pressed during the standby OFF mode, the unit goes to the standby ON mode.

Still Timer Setting

In order to protect the tape and VTR helical heads, it is recommended that the Still Timer be set for automatic tape protection mode in 30 seconds or under.

Page 67 indicates the settings for menu item 400-Still Timer set. Still Timer settings 4 and below will best protect the tape.

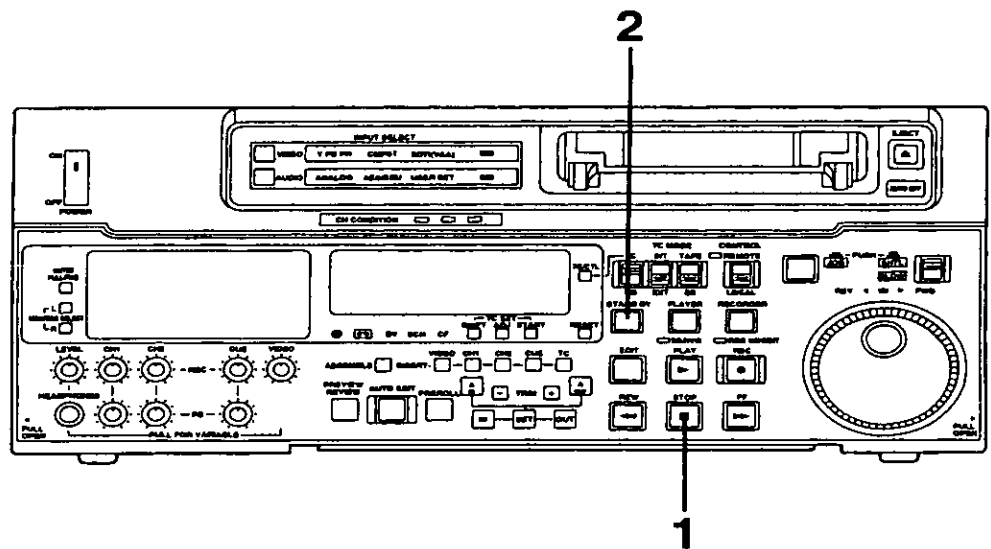

Recording

- 1** Set the accidental erasure prevention tab on the cassette tape to the "recording" position and insert the tape.
- 2** Press the STOP button to place the unit in the stop mode.
- 3** Set the TAPE/EE switch to EE.
EE images now appear on the TV monitor.
- 4** Check that the REC INHIBIT lamp is off.
If this lamp is lighted, set the REC INHIBIT switch to OFF.
- 5** Select the video and audio input signals and adjust their levels.
 - 5-1 Selecting video/audio input signals**
 - 1** Connect the signals to be recorded.
 - 2** Select the input signals using the INPUT SELECT switches on the front panel.
The input signals corresponding to the lighted lamps have been selected.
 - 5-2 Adjusting the video level**
 - 1** Normally, the adjustment control **49** for the video input level should be pressed in. (unity value)
The video signals will be recorded at the proper level.
 - 2** To adjust the recording level, pull out the adjustment knob and adjust in the +3 dB to -3 dB range.
 - 5-3 Adjusting the audio level**
 - 1** Adjust the audio input signal levels of the analog audio CH1/CH2 signals and analog cue signal. Keep the audio input/output level controls **49** pushed in (unity value).
The audio signals will be recorded at the proper level.
 - 2** To adjust the recording level, pull out the controls and adjust them. With the CUE signal, adjust the control in such a way that -20 dB will not be exceeded.
- 6** Press the REC and PLAY buttons together. The REC and PLAY lamps light, and recording commences.
- 7** To end the recording, press the STOP button.
Recording is ended, and the unit goes into the stop mode.

<Notes>

- Check that the SERVO lamp is lighted during recording. If it flashes or if it is off, the images played back will be disturbed.
- Only the analog composite video input signals can be adjusted. (The digital video and analog component input signals cannot be adjusted.)
- The sound and pictures to be recorded are offset from the playback pictures by 5 frames and recorded. When, for instance, recording sound at a particular timing while the playback pictures are monitored, the sound to be recorded will be recorded at a position which is offset from the playback pictures by 5 frames.

Playback

- 1** Insert the cassette tape, and place the unit in the stop mode.
- 2** Press the PLAY button.
Regular playback is now commenced.
- 3** Adjust the audio playback level.
Pull out the audio level controls and turn them clockwise or counterclockwise to adjust the levels. Normally, they are kept in the pushed-in state (unity value).
- 4** To end playback, press the STOP button.
The VTR now goes into the stop mode.

<Note>

Check that the SERVO lamp is lighted during playback. If it flashes or if it is off, the images played back will be disturbed.

Jog/shuttle

Jog mode

- 1** Push the search dial to the "in" position.
Be sure that the JOG lamp lights.
- 2** Rotate the search dial.
The dial's clickstops are cleared, and the tape is played back at the speed corresponding to the speed at which the dial is turned. The maximum speed can be selected using the setup menu No. 320 (JOG FWD MAX) and No. 321 (JOG REV MAX) settings. When the dial rotation is stopped, a still picture appears. The playback picture is noise-free.
- 3** To transfer from the jog mode to another mode, press the appropriate button.

Shuttle mode

- 1** Push the search dial to release it from the "in" position. The SHTL lamp lights, and the unit goes into the shuttle mode.
 - Immediately after the power has been turned on, rotate the search dial and set it to the center position.
- 2** Set the SHTL/SLOW switch to SHTL or SLOW.
- 3** Rotate the search dial.
When the SHTL/SLOW switch has been set to SHTL, the playback picture speed is varied from 0 to $\pm 60\times$ normal speed depending on the position of the dial. The playback picture speed can be switched to $\pm 16\times$, $\pm 32\times$ and $\pm 60\times$ normal speed with setting menu No. 101 (SHTL MAX).
The dial's center position is a clickstop where a still picture appears as the playback image. When the SHTL/SLOW switch has been set to SLOW, the playback picture speed is varied from -4 to $+4\times$ normal speed depending on the position of the dial. The maximum speed can be selected using the setup menu No. 317 (VAR FWD MAX) and No. 318 (VAR REV MAX) settings. However, noise appears at speeds other than -0.43 to $+1\times$ normal speed.
The dial's center position is a clickstop where a still picture appears as the playback image. The playback picture is noise-free.
- 4** To transfer from the shuttle mode to another mode, press the STOP button or other button.

<Note>

When the unit leaves the factory, its operation is set up so that it will be transferred to the shuttle or jog mode when the search dial is rotated. If it is inconvenient for operation to be transferred to the variable-speed mode directly, it can also be transferred through the search button.

Set setting menu No. 100 (SEARCH ENA) to KEY.

Manual editing

- 1** Select the editing mode.
ASSEMBLE: For assemble editing.
INSERT: For insert editing.
- 2** Select the editing channel.
In the case of insert editing, press the channel button corresponding to the signals to be edited, and check that its lamp is on.
- 3** Press the PLAY button.
- 4** Search for the position where the editing is to be commenced (IN point) while viewing the TV monitor, and press the PLAY and EDIT buttons together at the IN point.
- 5** Press the STOP or PLAY button at the position where editing is to be completed (OUT point) while viewing the TV monitor. The unit goes into the stop mode, and editing is completed.

<Note>

The sound and pictures to be recorded are offset from the playback pictures by 5 frames and recorded. When, for instance, recording sound at a particular timing while the playback pictures are monitored, the sound to be recorded will be recorded at a position which is offset from the playback pictures by 5 frames.

Preroll

- 1** Press the PREROLL button.
The VTR now performs the preroll operation.
 - When the edit IN point has been entered, the tape is rewound from the edit IN point for the duration set by setting menu "000," and the unit then goes into the stop mode.
 - When the edit IN point has not been entered, the tape is rewound for the duration set by setting menu "000" from the position where the button was pressed, and the unit then goes into the stop mode.

<Notes>

- The time code or CTL signal must be continuously recorded between the edit IN point and preroll point.
- When the IN point has not been entered, whether to enter the IN point and perform preroll or to perform preroll without entering the IN point can be selected at setting menu No. 311 (AUTO ENTRY).

Automatic editing (Deck to Deck)

Editing refers to the job of using a prerecorded tape to produce a complete recording by joining together separate cuts and deleting unnecessary parts.

The basic steps taken for editing are as follows.

- 1** Set the CONTROL switch to REMOTE on the player and to LOCAL on the recorder.
- 2** Select the editing mode.
- 3** Enter the edit points of the recorder and player.
- 4** Check and modify the edit points.
- 5** Check (Preview) before proceeding with the editing.
- 6** Proceed with the editing.
- 7** Check (Review) the recording that has resulted from the editing.

Automatic editing

Switch settings and adjustments

When the unit is used as the recorder:

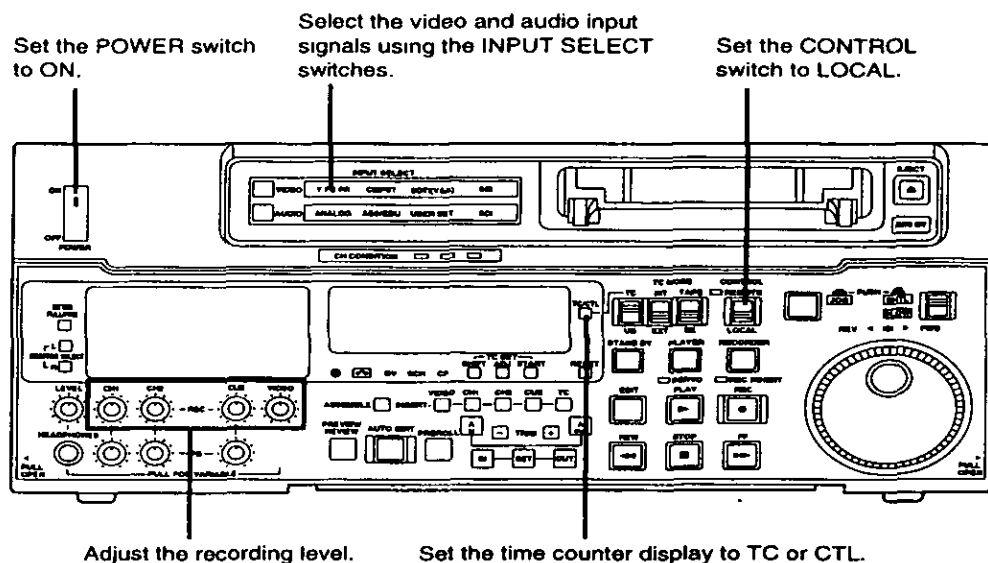

When the unit is used as the player:

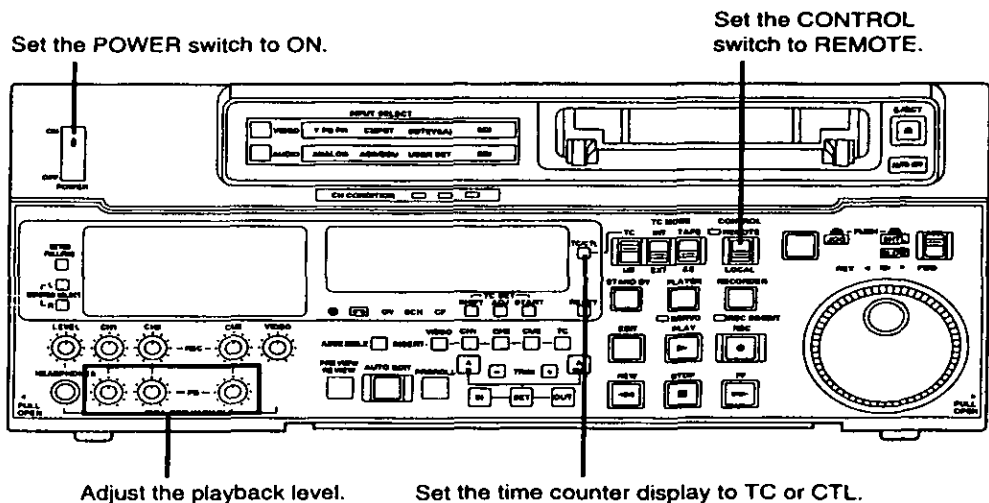

Select the editing mode

- 1** Select the editing mode.
For assemble editing, press the ASSEMBLE button.
For insert editing, press the INSERT button.
ASSEMBLE: The assemble editing mode (in which cuts are joined together) is established.
INSERT: The insert editing mode (in which cuts are inserted) is established.
- 2** Select the editing channel.
With assemble editing, the ASSEMBLE lamp lights.
With insert editing, press the button of the channel whose signals are to be edited and lights its lamp.
- 3** Select the VTR to be operated (this setting is performed when editing with 2 VTRs).
Press the PLAYER or RECORDER button to select the VTR.
PLAYER: Press this button to operate the player VTR and enter the edit points.
RECORDER: Press this button to operate the recorder VTR (this unit) and enter the edit points.

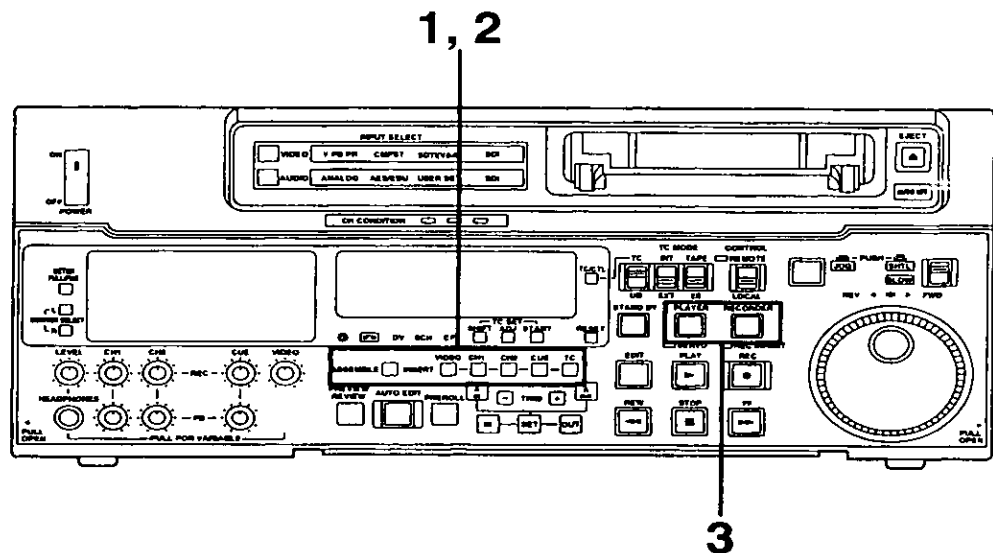

Automatic editing

Entering the edit points

- 1** Search for the edit IN point by performing the jog or shuttle operation. Establish the still picture mode at the desired position. Refer to page 28 for details on the jog/shuttle operations.
- 2** Press the SET button while holding down the IN button. The edit IN point is now entered. The edit IN point value now appears on the display.
- 3** Search for the edit OUT point by performing the jog or shuttle operation. Establish the still picture mode at the desired position. Refer to page 28 for details on the jog/shuttle operations.
- 4** Press the SET button while holding down the OUT button. The edit OUT point is now entered. The edit OUT point value now appears on the display.

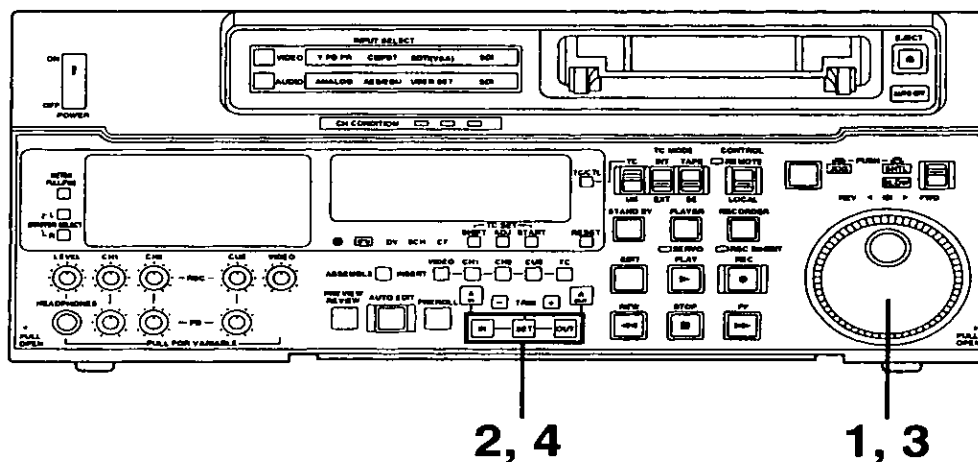

Match frame processing function

When using two VTRs for editing, a total of four edit points—namely, the player's IN and OUT points and the recorder's IN and OUT points—need to be entered. However, since the last edit point is calculated automatically, only three of these edit points must be entered.

Negative duration function

This function is used by combining setup menu No. 301 (IN/OUT DEL) and No. 302 (NEGA FLASH) described on page 63.

Checking the edit points

- 1** Press the IN (or OUT) button to check the edit point.
The value of the entered edit point appears on the display.
- 2** Press the PREROLL button while holding down the IN (or OUT) button to check the image at the edit point.
The tape is cued at the edit IN (or OUT) point, and the still picture mode at that point is displayed.
 - The EE mode is established if the TAPE/EE switch has been set to the "EE" position when "STOP" has been selected for the setup menu No. 313 (AFTER CUE-UP).
- 3** Press and hold down the IN and OUT buttons together to check the edit duration.
The duration time appears on the display.

Calculating the duration

- When both edit points have been set, the duration between the two edit points.
- When only one edit point has been set, the duration between the set data and the current tape address.
- When neither edit point has been set, the duration of the previously edited interval.

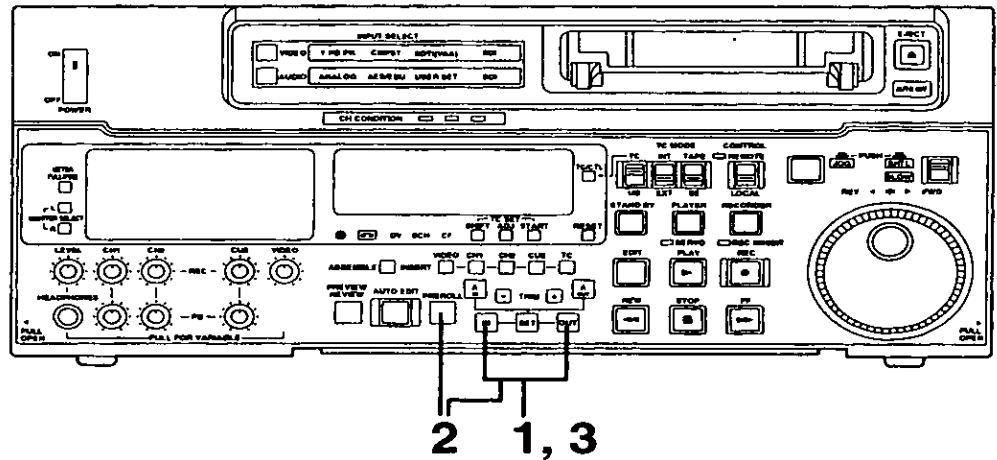

Automatic editing

Modifying the edit points

- 1** Re-entering the edit points
Search for the new edit point by performing the jog or shuttle operation, and press the IN (or OUT) and SET buttons together to re-enter the edit point.
- 2** Modifying the edit point in frame units (trim function)
Press the TRIM button while holding down the IN (or OUT) button.
The edit point is put ahead by 1 frame each time the + button is pressed.
The edit point is put back by 1 frame each time the – button is pressed.
- 3** Resetting the edit points
 - 3-1** Resetting both the edit IN and OUT points
 - Press the RESET button.
 - 3-2** Resetting either the edit IN or OUT point
 - Press the RESET button while holding down the IN (or OUT) button.

<Notes>

- Edit points can be reset only in the CTL mode.
- An edit OUT point can be reset even while editing is in progress.
- The IN and OUT points are automatically reset during the eject mode.

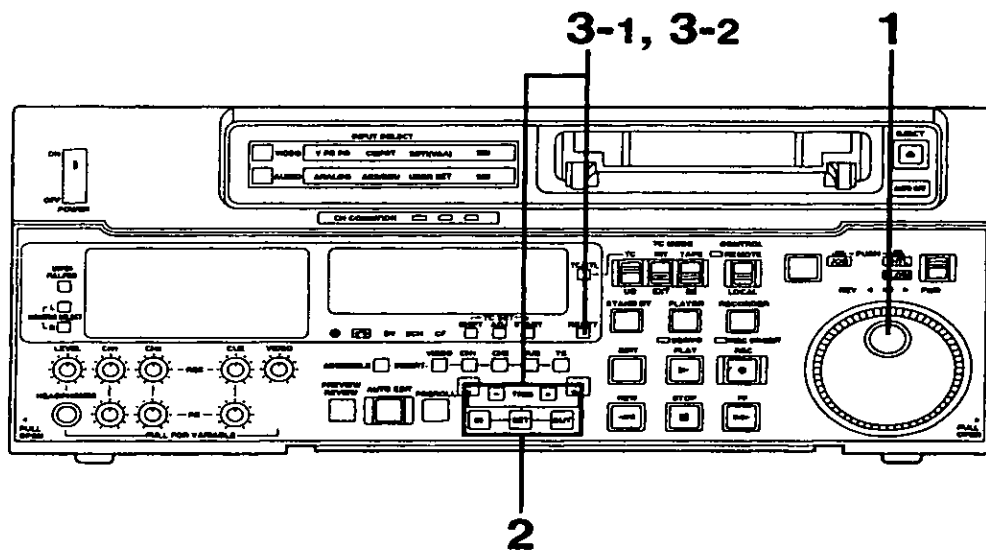

Preview

- 1 After the edit points have been entered, press the PREVIEW button. Normal preview is now performed.

<Notes>

- If the edit IN point has not been entered, the position where the PREVIEW button was pressed will be entered at the edit IN point.
- To stop the preview at any time, press the STOP button.
- If the PREVIEW button is pressed again while preview is in progress after the IN point, preview will start again from the beginning.
- When the edit OUT point is reached, the unit automatically goes into the stop mode.

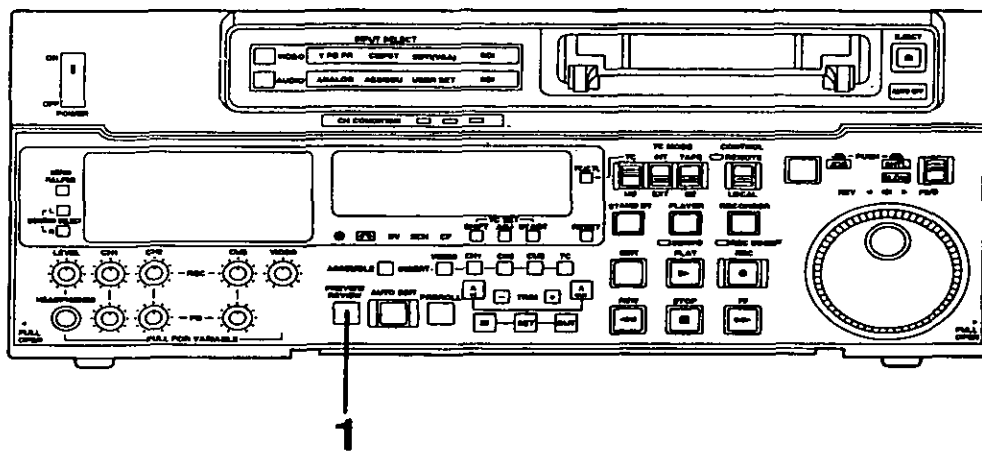

Automatic editing

Executing automatic editing

- 1 Press the AUTO EDIT button.
Automatic editing is now performed.
 - To stop the editing at any time, press the STOP button.
 - When the edit OUT point is reached, the unit goes into the stop mode after postrolling.

Postroll

With assemble editing, editing continues for approx. 2 seconds even after the edit OUT point has been passed, the tape is rewound to the OUT point, and the unit goes into the stop mode.

With insert editing, the unit goes into the play mode after the edit OUT point has been passed, the tape is rewound to the OUT point, and the unit goes into the stop mode.

Retry function

If the AUTO EDIT button is pressed again after the STOP button has been pressed to stop the editing, editing will start again from the beginning.

Auto tag editing

If the AUTO EDIT button is pressed when the next edit point has not yet been entered upon completion of editing, the previous edit OUT point will be entered as the IN point, and editing is performed accordingly.

To release the auto tag mode, press one of the tape transport buttons (PLAY, etc.).

<Note>

The entered points are automatically cleared after editing is executed. However, the previous editing points can be recalled by pressing the TRIM+ (or TRIM-) and SET buttons together.

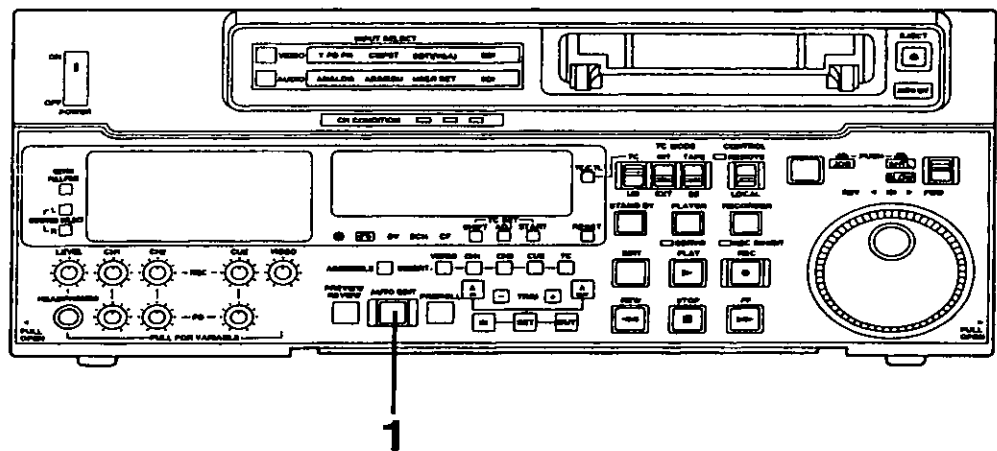

Review

- 1 Upon completion of the editing, press the **REVIEW** button.
The review is started in the recorder.
 - To stop the review at any time, press the **STOP** button.
 - When the edit **OUT** point is reached, the unit goes into the stop mode after postrolling.

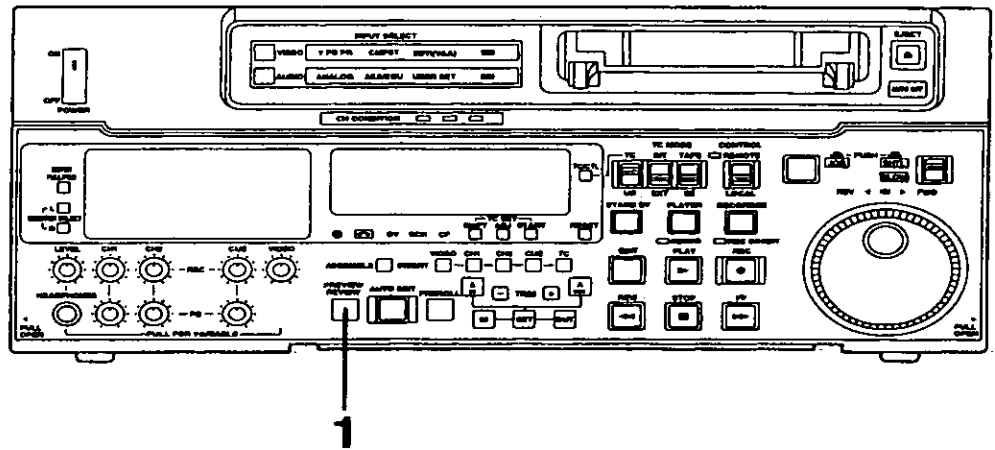

Split editing

Split editing refers to editing where the editing channels are switched while insert editing is in progress.

- 1** Perform insert editing.
- 2** Switch the editing channel.
When, for instance, sound from AUDIO CH2 is to be additionally inserted during video channel insert editing:

2-1 Press the AUDIO CH2 button during video channel editing.
The lamp in the button lights and the AUDIO CH2 sound is insert edited.

2-2 Press the AUDIO CH2 button again and turn off the lamp in the button.
This completes the AUDIO CH2 insert editing.

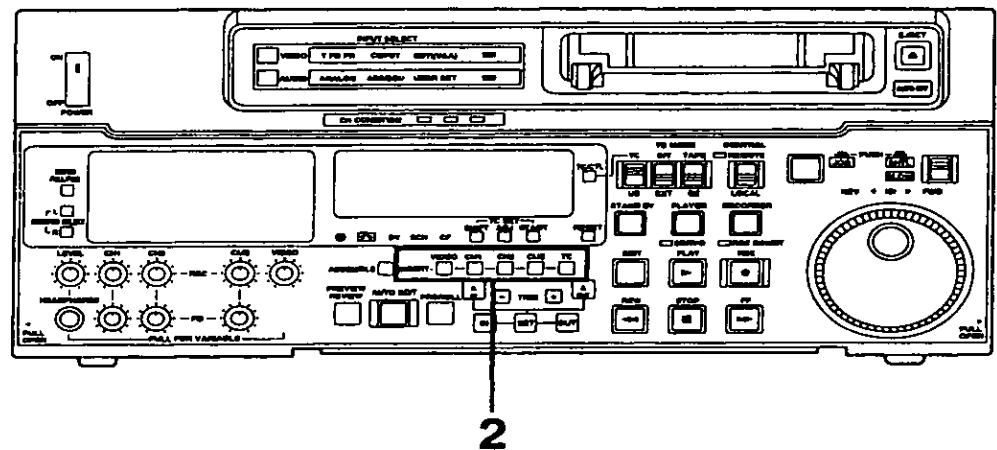

Audio split editing

The video edit points and audio edit points can be entered separately, and they can be offset from each other and edited.

Audio edit points can be entered, deleted and revised only when the insert editing mode has been selected. After the edit points have been entered, follow the same operating procedure as that for insert editing.

■ Entering the edit points

Video IN point: Press the SET button while holding down the IN button.

Video OUT point: Press the SET button while holding down the OUT button.

Audio IN point: Press the SET button while holding down the A IN button.

Audio OUT point: Press the SET button while holding down the A OUT button.

■ Deleting the edit points

Video IN point: Press the RESET button while holding down the IN button.

Video OUT point: Press the RESET button while holding down the OUT button.

Audio IN point: Press the RESET button while holding down the A IN button.

Audio OUT point: Press the RESET button while holding down the A OUT button.

■ Modifying the edit points

Video IN point: Press the TRIM+ or TRIM- button while holding down the IN button.

Video OUT point: Press the TRIM+ or TRIM- button while holding down the OUT button.

Audio IN point: Press the TRIM+ or TRIM- button while holding down the A IN button.

Audio OUT point: Press the TRIM+ or TRIM- button while holding down the A OUT button.

■ Indicating audio split editing

When the audio edit points are entered, " * " appears superimposed on the front panel and TV monitor to denote audio split editing.

TCR 00:00:00:00
* AUTO EDIT

This denotes audio split editing.

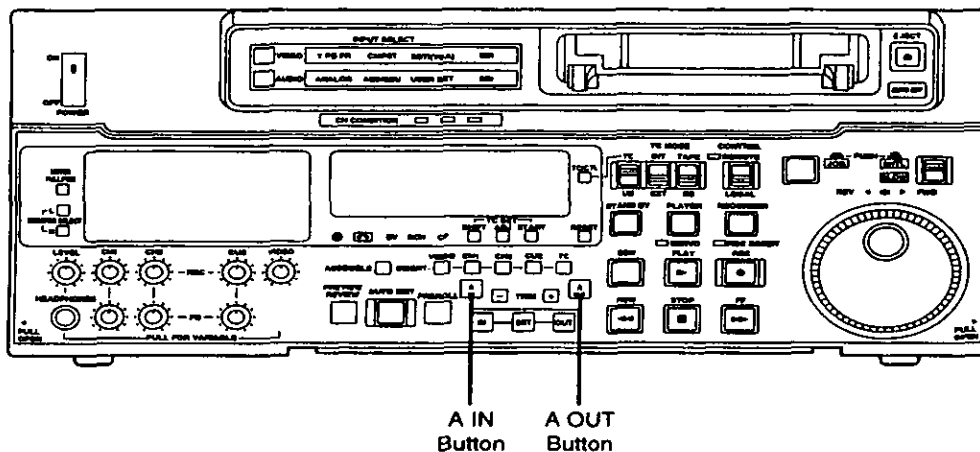

Audio split editing

■ Displaying the audio split edit points

The edit points are displayed on the front panel as shown below. (The figure shows an audio IN point.)

Operations

- Video IN point:** Press the IN button.
Video OUT point: Press the OUT button.
Audio IN point: Press the A IN button.
Audio OUT point: Press the A OUT button.

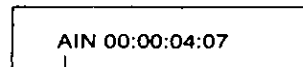

AIN 00:00:04:07

IN, OUT, AIN (audio IN point), AOUT (audio OUT point)

<Note>

If the editing mode is switched to assemble editing after audio edit points have been entered, these points will be deleted.

■ Cueing up the tape to the edit points

- Cue-up to video IN point:** Press the PREROLL button while holding down the IN button.
Cue-up to video OUT point: Press the PREROLL button while holding down the OUT button.
Cue-up to audio IN point: Press the PREROLL button while holding down the A IN button.
Cue-up to audio OUT point: Press the PREROLL button while holding down the A OUT button.

■ Duration display

The duration can be displayed on the front panel only.

Duration from video IN point to OUT point: Press the IN and OUT buttons simultaneously.

Duration from audio IN point to OUT point: Press the A IN and A OUT buttons simultaneously.

Match frame processing mechanism

When two VTRs are used for audio split editing operations, there will be a total of eight edit points: two pairs of video IN and OUT points, one for the player and the other for the recorder, and two pairs of audio IN and OUT points, one for the player and the other for the recorder. Since the remaining three points are automatically calculated when five of these eight edit points are entered, up to five edit points can be entered.

<Note>

If, during audio split editing, only the video OUT point (or audio OUT point) is entered and automatic editing is executed without the audio IN point (or video IN point) having been entered, editing will continue until the audio OUT point (or video OUT point) is entered or the STOP button is pressed to suspend operation.

Voice-over facility (internal)

Operating procedure 1

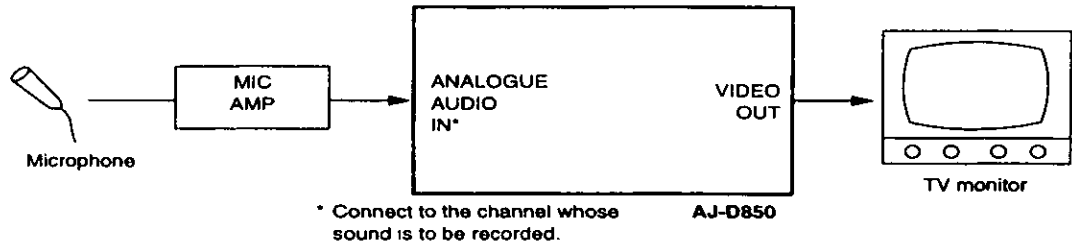

- 1** Select INT_VO as the setup menu No. 322 (AUD MEM MODE) setting.
- 2** Select the same setting for the channel (CH1 or CH2) on which the sound is to be recorded and for the setup menu No. 323 (AUD MEM CH) channel.
- 3** Insert the cassette tape for which the voice-over editing is to be performed.
- 4** Press the insert button for the channel (CH1 or CH2) on which the sound is to be recorded and ensure that its lamp lights.
- 5** Press the PLAY button.
- 6** Search the position (IN point) where voice-over editing is to start while watching the TV monitor.
- 7** Press the IN and SET buttons simultaneously at the IN point.
- 8** Input the audio signals to be recorded to the channel which was selected in step 2.
- 9** Search the position (OUT point) where voice-over editing is to end while watching the TV monitor.
- 10** Press the A OUT and SET buttons simultaneously at the OUT point. The audio signals to be recorded are stored in the memory.
- 11** Press the STOP button.
- 12** Press the AUTO EDIT button to proceed with editing. The audio signals stored in the memory are recorded from the memory onto the cassette tape.

<Note>

The audio signals can be previewed prior to editing by pressing the PREVIEW button while the SET button is held down before the AUTO EDIT button is pressed.

Voice-over facility (internal)

Operating procedure 2

- 1 Select INT_VO as the setup menu No. 322 (AUD MEM MODE) setting.
- 2 Select the same setting for the channel (CH1 or CH2) on which the sound is to be recorded and for the setup menu No. 323 (AUD MEM CH) channel.
- 3 Insert the cassette tape for which the voice-over editing is to be performed.
- 4 Press the insert button for the channel (CH1 or CH2) on which the sound is to be recorded and ensure that its lamp lights.
- 5 Enter the IN and OUT points of the positions where voice-over editing is to be performed.
- 6 Press the PREVIEW button.
- 7 While watching the TV monitor, input the audio signals to be recorded between the IN point and OUT point into the channel which was selected in step 2. The audio signals to be recorded are stored in the memory.
- 8 Press the AUTO EDIT button to proceed with editing. The audio signals stored in the memory are recorded from the memory onto the cassette tape.

<Note>

The audio signals can be previewed prior to editing by pressing the PREVIEW button while the SET button is held down before the AUTO EDIT button is pressed.

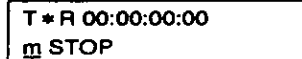

T * R 00:00:00:00
m STOP

“m” indicates the edit mode in which the internal memory is used.

<Notes>

Memory capacity

- Up to 20 seconds of sound can be stored in the unit's internal memory. It should be borne in mind that even if an attempt is made to store more than 20 seconds of sound in the memory, all the audio signals in excess of the memory's 20-second capacity will fail to be stored.
- When INT_VO or INT_X, which is performed using the internal memory in the setup menu No. 322 (AUD MEM MODE) setting, “m” appears on the front panel and is superimposed onto the TV monitor display to indicate that the editing mode using the internal memory is now being used.

For operation with an editing controller (AG-A850)

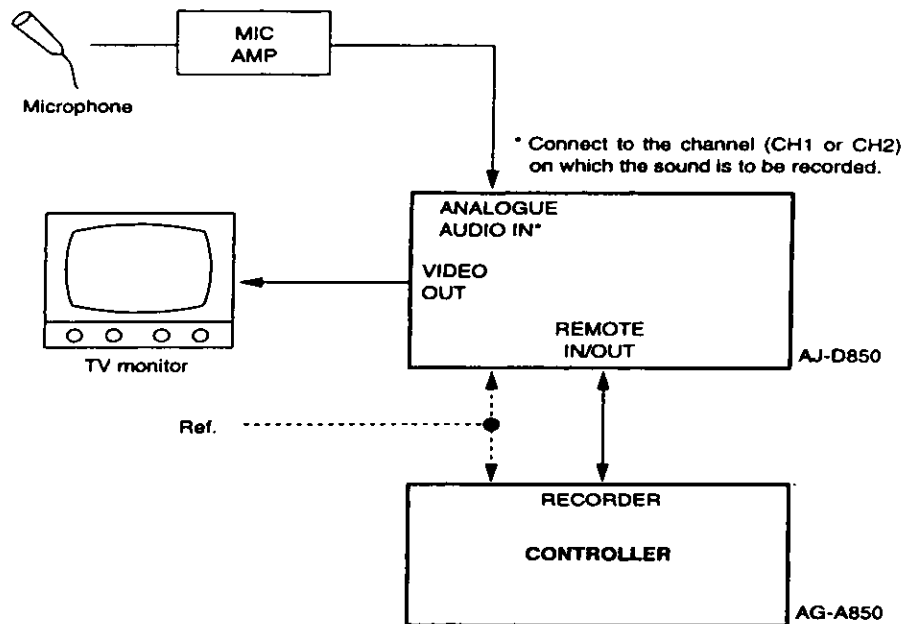

- 1** Select INT_VO as the setup menu No. 322 (AUD MEM MODE) setting.
- 2** Select the same setting for the channel (CH1 or CH2) on which the sound is to be recorded and for the setup menu No. 323 (AUD MEM CH) channel.
- 3** Insert the cassette tape for which the voice-over editing is to be performed into the VTR.
- 4** Set the CONTROL switch on the VTR to the REMOTE position.
- 5** Set the controller's SOURCE selector to AUX1.
- 6** Press the insert button for the channel (CH1 or CH2) on which the sound is to be recorded.
- 7** Enter the IN and OUT points of the positions where voice-over editing is to be performed.
- 8** Press the PREVIEW button.
- 9** While watching the TV monitor, input the audio signals to be recorded between the IN point and OUT point into the channel that was selected in step 6. The audio signals to be recorded are stored in memory.
- 10** Press the AUTO EDIT button to proceed with editing. The audio signals stored in the memory are recorded from the memory onto the cassette tape.

<Note>

For further details on the AG-A850, refer to the operating instructions of the AG-A850.

Audio cross channel editing (internal)

Example: To record cross-faded audio signals onto CH2

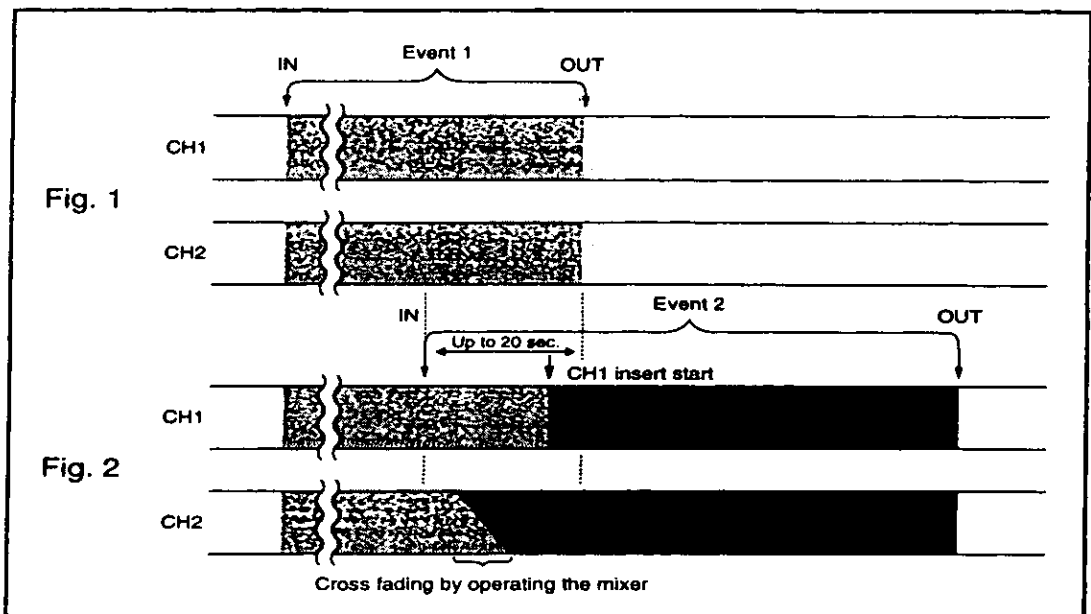
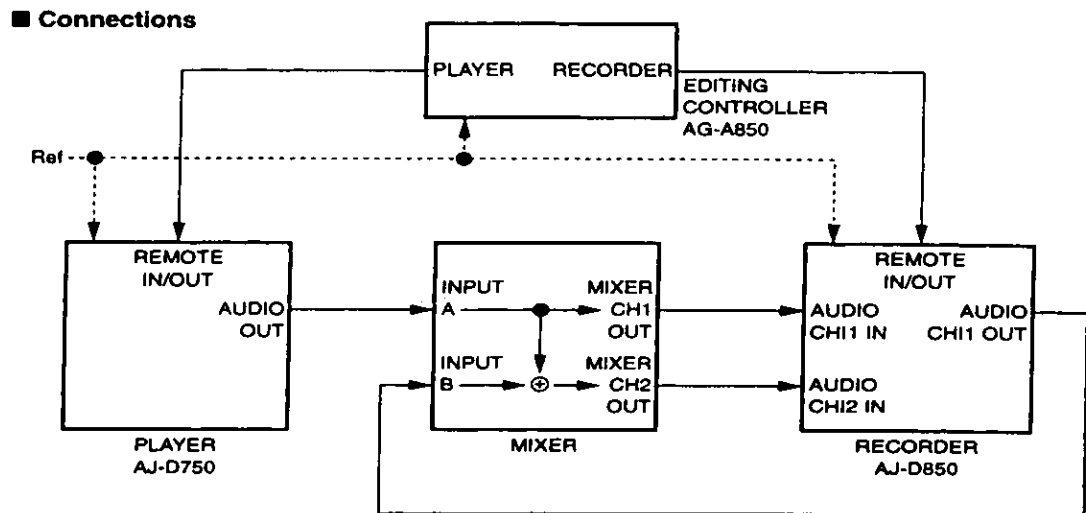

- 1 Select INT_X as the setup menu No. 322 (AUD MEM MODE) setting.
- 2 Select CH2 as the setup menu No. 323 (AUD MEM CH) setting.
- 3 Select the audio CH1 and CH2 in the insert editing.
 <Note>
 Select the video as well if the video signals are also going to be edited.

-
- 4** Enter the edit points of the first event on the player's tape.
 - 5** Enter the edit points of the first event on the recorder's tape.
 - 6** Operate the mixer in such a way that the player's audio output signals are output from the mixer's CH1 OUT and CH2 OUT connectors. (The same audio signals will be delivered through CH1 and CH2 of the mixer.)
 - 7** Press the AUTO EDIT button. The first event is now recorded on the recorder's tape. (See Fig. 1.)
The last 20 seconds (which is the capacity of the memory) of the audio signals before the OUT point are now saved in the memory.
 - 8** Release the insert button for CH1 so that only the insert button for CH2 is engaged.
<Note>
Select the video as well if the video signals are also going to be edited.
 - 9** Enter the edit point of the next event on the player's tape.
 - 10** Enter the edit point of the next event on the recorder's tape.
<Note>
The IN point must be set up to 20 seconds (more than the cross fading duration) before the previous edit OUT point.
 - 11** Operate the mixer in such a way that the player's audio output signals are output from the mixer's CH1 OUT connectors and that the recorder's (this unit) CH1 OUT audio signals are output from the mixer's CH2 OUT connectors. [The recorder's (this unit) CH1 OUT signals are the audio signals supplied from the internal memory.]
 - 12** Press the AUTO EDIT button.
 - 13** Operate the mixer starting at the IN point, and change the mixer's CH2 OUT signals gradually from the recorder's CH1 OUT audio signals into the player's audio output signals for the mixer's CH2 OUT connectors. (Cross fading)
 - 14** Press the CH1 insert button after the mixer's CH2 output signals have been changed into the player's audio output signals. The STOP mode is established at the OUT point, and the last 20 seconds (which is the capacity of the memory) of the audio signals before the OUT point are now saved in the memory. (See Fig. 2.)
 - 15** To continue editing, repeat steps 8 to 14.

<Notes>

Before attempting to perform voice-over editing or audio cross channel editing using the audio memory unit (AJ-YA752, option), proceed with the following settings for the unit (AJ-D850).

1. Select either AMU_X or AMU_VO as the setup menu No. 322 (AUD MEM MODE) setting.
2. For audio cross channel editing, set the channel on which the signals are to be recorded on setup menu No. 323 (AUD MEM CH).
3. Proceed with operation, using the AJ-YA752 operating instructions as a reference.

V blanking data recording/playback

■ Additional line recording/playback function

- Select the mode for recording signals in additional lines using setup menu item No. 800 (ADD LINE).
 - Off:** No signals are recorded in additional lines.
 - YC422:** The input signals are recorded in 1 line in the 422 mode.
 - YC411:** The input signals are recorded in 1 line in the 411 mode.
 - Y1_B/W:** The input signals are recorded in 1 line in their original form as the luminance signal.
 - Y1_PBF:** The input signals are separated into the Y (luminance) and C (chrominance) signals, and only the Y signal is recorded in 1 line.
 - C1:** The input signals are separated into the Y (luminance) and C (chrominance) signals, and only the C signal is recorded in 1 line.
 - Y2_B/W:** The input signals are recorded in 2 lines in their original form as the luminance signal.
 - Y2_PBF:** The input signals are separated into the Y (luminance) and C (chrominance) signals, and only the Y signal is recorded in 2 lines.
 - C2:** The input signals are separated into the Y (luminance) and C (chrominance) signals, and only the C signal is recorded in 2 lines.
- Select the additional lines for recording on the sub-menu screen.
- The number of lines in which the teletext signals can be recorded differs depending on which mode for recording the signals in the additional lines has been selected.

■ Teletext signal recording/playback function

- Up to 28 lines per frame of the teletext signals which are input can be recorded and played back.
- The number of lines in which the signals can be recorded differs depending on the setup menu item No. 800 (ADD LINE) setting.
- Depending on the setup menu item No. 800 (ADD LINE) setting, it may not be possible to record the input teletext signals in all of the lines.
- Listed below are the numbers of lines per frame in which the signals can be recorded in each mode.

Mode	Additional lines	Teletext signals
Off	0 line/frame	28 lines/frame
YC422	1 line/frame	15 lines/frame
YC411	1 line/frame	20 lines/frame
Y1_B/W	1 line/frame	28 lines/frame
Y1_PBF	1 line/frame	28 lines/frame
C1	1 line/frame	28 lines/frame
Y2_B/W	2 lines/frame	15 lines/frame
Y2_PBF	2 lines/frame	15 lines/frame
C2	2 lines/frame	15 lines/frame

<Note>
There is some limitation to the number of lines in which signals can be recorded with the recording and playback function of the V blanking data.

AJ-D850P

Video output (encoder output) signal adjustments

After this system has been connected, the video output signal (ENCODER OUT) must be adjusted if AB roll editing (editing using two source machines) using an editor, for instance, is to be error-free and accurate. (This adjustment must be repeated when one of the connecting cables has been replaced and whenever the connections are changed.)

The adjustment procedure using this unit is outlined below.

- 1** Check the connections. (See page 22.)
- 2** Set the REMOTE/LOCAL switch  on the front panel bottom section to the adjustment position (LOCAL).
REMOTE: For adjusting the video output signals using an external encoder remote controller.
LOCAL: For adjusting the video output signals using this unit.

- 3** Adjust the source machine independently.

3-1 When using the preset values

Set the PRESET/MANUAL switches of the VIDEO LEVEL, CHROMA LEVEL, SETUP and HUE controls to PRESET.

3-2 When adjusting the video output signals without using the preset values

- 1** Play back a cassette tape on which standard color bar signals have been recorded.
- 2** Adjust the controls in such a way that the waveforms on the waveform monitor (WFM) and vectorscope (VSC) resemble those shown in the figures below.

A Setup level

Adjust the control to eliminate deviation.

B Video level

Adjust this level to 100 IRE.

C Chroma level and hue

Adjust the two controls in such a way that the light spot of the vector waveforms comes inside the rectangular grid mark.

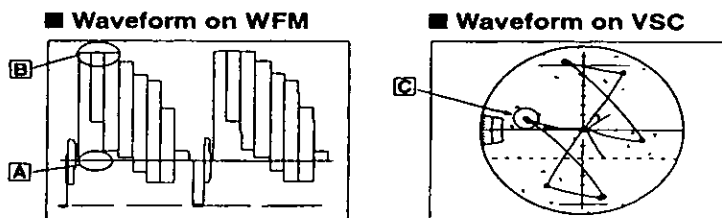

- 4** Perform the same adjustments on the source machine connected to the unit.

Setup (default settings)

The unit's major settings are performed by making selections on menus. The setting menus appear on the TV monitor when the TV monitor and VIDEO OUT 3 connector in the unit's connector area are hooked up.

Changing the settings

- 1** Press the MENU button.
The setup menu appears on the TV monitor and setup menu No. appears on the counter display. (If the setup has already been performed, the screen showing the changes made last will appear.)
- 2** Rotate the search dial and select the item to be set.
The cursor (*) on the menu screen moves and the item No. on the display flashes.
 - When the dial is rotated clockwise, the item No. is incremented from 001→002→003→004 and so on; when it is rotated counterclockwise, the item No. is decremented.
 - The search dial should be used in jog mode if at all possible.
 - Hold down the PLAY button and press the FF (next major item) or REW (previous major item) buttons to select the menu by major item.
- 3** While holding down the search button, rotate the search dial at the position where the change is to be made.
The setting No. now flashes.
When the dial is rotated clockwise, the setting value is incremented; when it is rotated counterclockwise, it is decremented.
- 4** Release the search button when the setting is completed.
The setting value on the menu screen and display flashes.
 - During the SHTL mode, the item moves if the search dial is not at the STILL position.
- 5** Repeat steps 2 through 4 to change another item.
- 6** Press the SET button.
The changes are now stored in the memory.
 - To return the items to the settings established before the changes were made, press the MENU button.

To return the setup settings to the factory (default) settings, press the RESET button while the menu is displayed. **The following message will now appear:**

SETUP-MENU INIT SET
YES<PLAY>/NO<STOP>

When the PLAY button is pressed, the factory settings are restored.

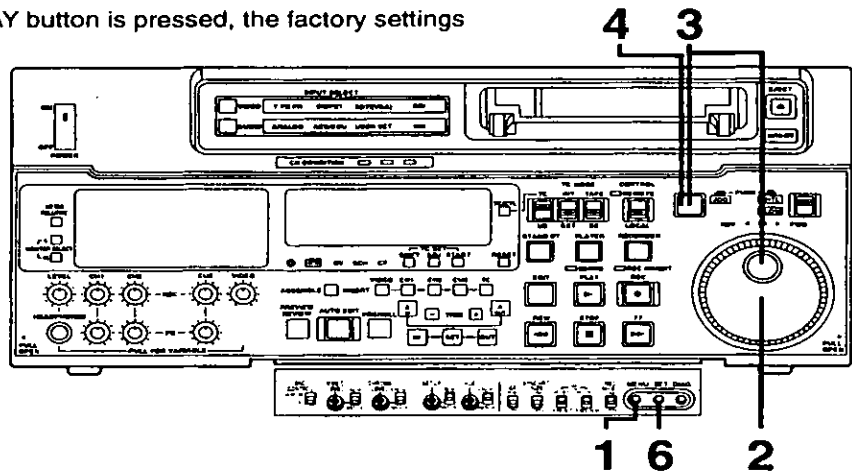

<Note>

- When the RESET button is pressed to return to the factory settings, the factory settings are restored only for the user file currently being used and other user files are not affected
- The changed SYSTEM menu contents are recorded even if the MENU button is pressed

Setup (setting) menus

This unit can store up to 5 user files (user 1 to user 5) containing different menu settings, and these files can be selected and used.

Changing the file

- 1** Press the MENU button.
- 2** Hold down the STAND BY button and press the FF button to switch to the next user file. Hold down the STAND BY button and press the REW button to switch to the previous user file.

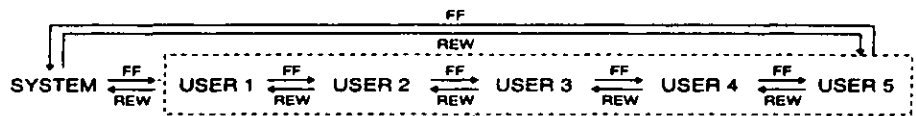

USER FILE

Each user file contains the following items.

- BASIC
- OPERATION
- INTERFACE
- EDIT
- TAPE PROTECT
- TIME CODE
- VIDEO
- AUDIO
- V BLANK
- MENU

- 3** Repeat the operation in step 2 to select the user file to be used and press the SET button. The user file is changed and stored in the memory.

<Note>

SYSTEM menu items are not included in user files 1 to 5.

Therefore, after selecting the user file, switch to the SYSTEM file and set the SYSTEM menu items.

Setup menus

Lock mode can be set to protect the settings in the system files and user files (USER2 – USER5). Settings can no longer be changed when this mode is set.

To set and release the lock mode for the system files and user files use setup item No. 30 (MENU LOCK) and setup menu item No. A03 (MENU LOCK), respectively.

Setting and releasing the lock mode.

- 1** Press the MENU button.
- 2** While holding down the STAND BY button, press the REW or FF button, and select the file for which the lock mode is to be set or released.
- 3** Turn the search dial and move the cursor (*) on the menu screen to setup item No. 30 (MENU LOCK) or setup menu item No. A03 (MENU LOCK) for the system or user file.
- 4** While holding down the search button, turn the search dial and select lock mode setting or release.
To set the lock: Select the 0001 (ON) setting.
To release the lock: Select the 0000 (OFF) setting.

When the lock has been set, "LOCKED" flashes on the menu screen. In addition, the counter display stops flashing and lights.

SETUP-MENU	LOCKED
<USER2>	No.000 - 0005
*000 P-ROLL TIME	5s
001 CHARA H-POS	5
002 CHARA V-POS	23
003 DISPLAY SEL	T&STA
004 LOCAL ENA	ST&EJ
005 TAPE TIMER	±12h
006 SUPER	ON
007 CHARA TYPE	WHITE
008 REMAIN SEL	OFF

- 5** Press the SET button. The setting is now stored in the memory.

<Notes>

- The lock mode cannot be set for the USER1 file settings.
- Even if the RESET button is pressed, the files which has been set to the lock mode cannot be reset to the factory settings.

The contents of the USER2 – USER5 files can be copied (loaded) into the USER1 file. In addition, the contents of the USER1 file can be copied (saved) to the USER2 – USER5 files.

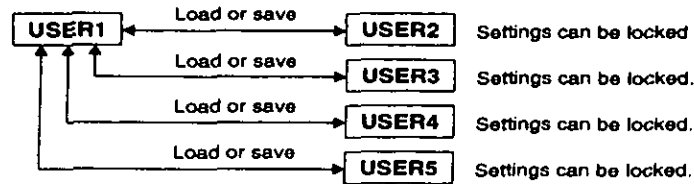

Loading a user file

- 1** Press the MENU button.
- 2** While holding down the STANDBY button, press the REW or FF button, and select USER1.
- 3** Turn the search dial and move the cursor (*) on the menu screen to setup item No. A00 (LOAD).

```

SETUP-MENU  MENU
<USER1>    NO.A00 - 0000
 803 TELETEXT DET  AUTO
*A00 LOAD          USER2
A01 SAVE          USER2
A02 P.ON LOAD     OFF
END
  
```

- 4** While holding down the search button, turn the search dial and select the user file whose contents are to be loaded into USER1.
- 5** Press the SET button. The following messages appear on the menu screen and counter display.

Menu screen

```

SETUP-MENU LOAD

USER2 → USER1 OK?
YES<PLAY>/NO<STOP>
  
```

Counter display

```

TCR 00:00:00:00
SETUP LOAD U-2 → U-1
  
```

The user file number selected in step 4 is displayed in the shaded area.

- 6** Press the PLAY button. The settings of the user file selected in step 4 are loaded, and the USER1 menu display appears. When the STOP button is pressed, the USER1 menu display appears while the settings remain unchanged.
- 7** Turn the search dial and move the cursor (*) on the menu screen to any setup item except No. A00 (LOAD) and No. A01 (SAVE).
- 8** Press the SET button. The USER1 settings are now stored in the memory. If the USER1 settings are not going to be stored in the memory, do not press the SET button but press the MENU button.

Setup menus

Saving a user file

- 1 Press the MENU button.
- 2 While holding down the STAND BY button, press the REW or FF button, and select USER1.
- 3 Turn the search dial and move the cursor (*) on the menu screen to setup item No. A01 (SAVE).

```
SETUP-MENU  MENU
<USER1>     NO.A00 - 0000
803 TELETEXT DET  AUTO
A00 LOAD                USER2
*A01 SAVE              USER2
A02 P.ON LOAD          OFF
END
```

- 4 While holding down the search button, turn the search dial and select the user file into which the USER1 contents are to be saved. User files which have been set to the lock mode are not displayed. When all the user files have been set to the lock mode, the "LOCKED" display appears and the contents cannot be saved.
- 5 Press the SET button. The following messages appear on the menu screen and counter display.

Menu screen

```
SETUP-MENU SAVE
USER1 → USER2 OK?
YES<PLAY>/NO<STOP>
```

Counter display

```
TCR 00:00:00:00
SETUP SAVE U-1 → U-2
```

The user file number selected in step 4 is displayed in the shaded area.

- 6 Press the PLAY button. The contents of the USER1 file are saved in the user file which was selected in step 4 and stored in the memory. When the STOP button is pressed, the USER1 menu display appears while the settings remain unchanged.
- 7 Turn the search dial and move the cursor (*) on the menu screen to any setup item except No. A00 (LOAD) and No. A01 (SAVE).
- 8 Press the SET button. The USER1 settings are now stored in the memory. If the USER1 settings are not going to be stored in the memory, do not press the SET button but press the MENU button.

Automatic loading of user file when the power is turned on

When the user file to be loaded is selected in advance using setup menu item No. A02 (P.ON LOAD), it can be automatically loaded into USER1 when the power is turned on.

Setup (setting) menus

SYSTEM menu

<SYSTEM>

Item		Setting		Description
No.	Superimposed display	No.	Superimposed display	
00	SYS SC	0000	-127	System phase adjustment: Total variable range: $\pm 180^\circ$ or more -: Advanced +: Delayed <Note> If setting operation is performed, the setting value does not return to factory (default) setting
		<u>0127</u>	0	
		0255	128	
01	SYS H	0000	-30	System phase adjustment: SC cycle phase (280 ns steps) -: Advanced +: Delayed <Note> If setting operation is performed, the setting value does not return to factory (default) setting
		<u>0032</u>	0	
		0060	30	
02	VIDEO PHASE	0000	-32	Video phase adjustment: 148 ns steps -: C advanced +: C delayed
		<u>0032</u>	0	
		0064	32	
03	YC COARSE	0000	-2	YC timing rough adjustment: 148 ns steps -: C advanced +: C delayed
		<u>0002</u>	0	
		0004	2	
04	YC FINE	0000	-2	YC timing fine adjustment: 37 ns steps -: C advanced +: C delayed (The digital OUT option YC does not change)
		<u>0002</u>	0	
		0004	2	
05	SCH COARSE	0000	0	SCH phase adjustment: 90° units (The S and C phases change but the H phase does not change.)
		0001	90	
		0002	180	
		0003	270	
06	SCH FINE	0000	-124	SCH phase adjustment: Total variable range: $\pm 45^\circ$ or more (The S and C phases change but the H phase does not change.)
		<u>0128</u>	0	
		0255	123	
07	Pe OUT LV	0000	-124	Component Pe output level adjustment: Total variable range: ± 3 dB
		<u>0124</u>	0	
		0247	123	
08	Pr OUT LV	0000	-124	Component Pr output level adjustment: Total variable range: ± 3 dB
		<u>0124</u>	0	
		0247	123	

The underline on the setting item denotes the initial setting.

AJ-D850P

Setup (setting) menus

SYSTEM menu

<SYSTEM> (continued)

Item		Setting		Description
No.	Superimposed display	No.	Superimposed display	
10	AV PHASE	0000 ⋮ <u>0128</u> ⋮ 0255	-128 ⋮ <u>0</u> ⋮ 127	This adjusts the audio output phase with respect to the video output: 20.8 μs steps -: The audio output phase is advanced with respect to the video output. +: The audio output phase is delayed with respect to the video output.
20	SYS H RANGE	0000 <u>0001</u>	FULL <u>FINE</u>	This selects the adjustable range for SYSTEM H during when the ENCODER REMOTE is connected. 0: ±8 μ sec (±30 steps) 1: -1.9 to +2.7 μ sec (-7 to +10 steps) <Note> If setting operation is performed, the setting value does not return to factory (default) setting.
21	SYS H OFFSET	0000 0001 0002 <u>0003</u> 0004 0005 0006	-3 -2 -1 <u>0</u> 1 2 3	System phase adjustment: 4.48 μs steps 0: -13.4 μ sec 1: -8.96 μ sec 2: -4.48 μ sec 3: 0 sec 4: +4.48 μ sec 5: +8.96 μ sec 6: +13.4 μ sec <Note> Factory settings will remain unchanged even if an attempt is made to perform a setting operation.
30	MENU LOCK	<u>0000</u> 0001	<u>OFF</u> ON	This selects whether the system file lock mode is to be engaged or released. 0: The lock is released (file data can be changed). 1: The lock is engaged (file data cannot be changed).

The underline on the setting item denotes the initial setting.

AJ-D850P

Setup menus

USER menu

<BASIC>

Item		Setting		Description
No.	Superimposed display	No.	Superimposed display	
000	P-ROLL TIME	0000 ⋮ <u>0005</u> ⋮ 0015	0S ⋮ <u>5S</u> ⋮ 15S	This sets the preroll time which can be set from 0 to 15 seconds in 1-second increments. <Note> When the unit is set to automatic editing [PREVIEW, AUTO EDIT], the unit will not operate if the preroll time is set to 0 seconds.
001	CHARA H-POS	0000 ⋮ <u>0005</u> ⋮ 0011	0 ⋮ <u>5</u> ⋮ 11	This sets the position of the characters on the horizontal plane for the time code and other super displays output to the VIDEO OUT 3 connector <Notes> 1. When setting this item, the DISPLAY SEL status is output to VIDEO OUT 3 even if SUPER OFF has been set. However, when the menu is exited, operation complies with the SUPER OFF/ON setting. Also, CHARA TYPE is output to VIDEO OUT 3 according to the status set in the menu. 2. When the DISPLAY SEL setting causes characters to extend beyond the edges of the screen, the setting value is changed so that the characters are automatically displayed in a position on the screen.
002	CHARA V-POS	0000 ⋮ <u>0018</u> ⋮ 0022	0 ⋮ <u>18</u> ⋮ 22	This sets the position of the characters on the vertical plane for the time code and other super displays output to the VIDEO OUT 3 connector <Notes> 1. When setting this item, the DISPLAY SEL status is output to VIDEO OUT 3 even if SUPER OFF has been set. However, when the menu is exited, operation complies with the SUPER OFF/ON setting. Also, CHARA TYPE is output to VIDEO OUT 3 according to the status set in the menu. 2. When the DISPLAY SEL setting causes characters to extend beyond the edges of the screen, the setting value is changed so that the characters are automatically displayed in a position on the screen.
003	DISPLAY SEL	0000 <u>0001</u> 0002 0003 0004 0005 0006	TIME <u>T&STA</u> T&S&M T&RT T&YMD T&MDY T&DMY	This is used to select what is to appear as the time code or other superimposed display at the VIDEO OUT 3 connector. 0: Time only 1: Time and operating status 2: Time, operating status and mode 3: Time and recording time 4: Time and recording date (year/month/day) 5: Time and recording date (month/day/year) 6: Time and recording date (day/month/year) <Notes> • "DVC PRO MODE," "DV MODE" or "DVCAM MODE" is displayed as the mode when a DVC PRO, DV or DVCAM format tape is used, respectively. • When setting 2 (T&S&M) is used, an error message will appear when a warning or error has occurred • The recording time and recording date are displayed only when a DV or DVCAM format tape is played back. The operating status is displayed when a DVC PRO format tape is played back

The underline on the setting item denotes the initial setting.

Setup menus

USER menu

<BASIC> (continued)

Item		Setting		Description
No.	Superimposed display	No.	Superimposed display	
004	LOCAL ENA	0000 <u>0001</u> 0002	DIS <u>ST&EJ</u> ENA	This selects the buttons which can be operated on the front panel when the REMOTE/LOCAL switch has been set to REMOTE. 0: No buttons can be operated. 1: Only the STOP and EJECT buttons can be operated. 2: All buttons except for the RECORDER and PLAYER buttons can be operated.
005	TAPE TIMER	<u>0000</u> 0001	<u>±12h</u> 24h	This selects the 12 or 24 hour display for the CTL counter. 0: 12 hour display 1: 24 hour display
006	SUPER	0000 <u>0001</u>	OFF <u>ON</u>	This selects whether the time code and other super display which are output to the VIDEO OUT 3 connector is to shown. 0: Not shown. 1: Shown.
007	CHARA TYPE	<u>0000</u> 0001	<u>WHITE</u> W/OUT	This selects the display type for the super display output to the VIDEO OUT 3 connector as well as for displays such as the setting menu, etc. 0: White characters against a black background. 1: White characters with a black border.
008	REMAIN SEL	<u>0000</u> 0001	<u>OFF</u> ON	This selects whether the remaining tape time is shown on the front panel. 0: Not shown. 1: Shown. When "T&S&M" is selected as the setup menu item No. 003 (DISPLAY SEL) setting, the remaining tape time is displayed on the third line of the VIDEO OUT 3 connector superimposed display in place of the mode display. <Note> Even when "1" (ON) is selected, the remaining tape time is not shown while the unit is calculating the remaining tape time after ejecting or inserting the cassette.
009	SETUP NUMBER	<u>0000</u> 0001	<u>OFF</u> ON	This selects whether the SETUP-MENU No. is displayed on the front panel. 0: The SETUP-MENU No. is not displayed. 1: The SETUP-MENU No. is displayed.
010	MONI CONTROL	<u>0000</u> 0001	<u>MANU</u> AUTO	This sets whether the recorder is to be forcibly set to the EE mode and the player's playback signals are to be output to the monitor by pressing the recorder's PLAYER button when a monitor has been connected only to the recorder during deck-to-deck editing. 0: The recorder is not forcibly set to the EE mode. 1: The recorder is forcibly set to the EE mode, and the player's playback signals are output.

The underline on the setting item denotes the initial setting.

AJ-D850P

USER menu

<OPERATION>

Item		Setting		Description
No.	Superimposed display	No.	Superimposed display	
100	SEARCH ENA	<u>0000</u> 0001	<u>—</u> DIAL KEY	This selects the direct search dial operation. 0: For direct search dial operations. 1: Operation is not transferred to the search mode unless the search button is pressed.
101	SHTL MAX	0000 <u>0001</u> 0002	×16 <u>—</u> ×32 ×60	This sets the maximum speed for shuttle operations 0: 16× normal speed 1: 32× normal speed 2: 60× normal speed <Note> During DV or DVCAM format, the maximum speed is 32× normal speed even when 60× is selected.
102	FF. REW MAX	0000 <u>0001</u> 0002	×32 <u>—</u> ×60 ×100	This sets the maximum speed for FF and REW operations. 0: 32× normal speed 1: 60× normal speed 2: 100× normal speed <Note> During DV or DVCAM format, the maximum speed is 32× normal speed regardless of this setting.
103	AUDIO MUTE	<u>0000</u> 0001	<u>—</u> OFF ON	This sets the status until the audio signal is output when operation switches from the stop or search modes to the play mode. 0: The time until the audio is output is shortened 1: The audio is output after the status stabilizes <Note> When set to 0 (OFF), the sound in the initially output part is incomplete. Therefore, this setting is not recommended for broadcasts.
104	REF ALARM	0000 <u>0001</u>	OFF <u>—</u> ON	This selects whether to warn the operator when the REF.VIDEO signal has not been connected. 0: Warning is not given. 1: Warning is given by the flashing STOP lamp.
105	AUTO EE SEL	<u>0000</u> 0001 0002	<u>—</u> S/F/R STOP BLACK	This selects the VTR mode in which the EE status is established when the TAPE/EE switch is set to EE. 0: EE status is established in the STOP, FF or REW mode. However, EE status is always established in EJECT mode regardless of the TAPE/EE switch setting. 1: EE status is established only in the stop mode. However, EE status is always established in EJECT mode regardless of the TAPE/EE switch setting. 2: EE status is established only in the stop mode. However, depending on TAPE/EE switch setting EJECT mode is as follows: TAPE/EE switch EE: EE status TAPE/EE switch TAPE: BLACK status for video MUTE status for audio
106	PLAY DELAY	<u>0000</u> ⋮ 0015	<u>—</u> 0 ⋮ 15	This set the play delay time in frame increments.

The underline on the setting item denotes the initial setting.

Setup menus

USER menu

<OPERATION> (continued)

Item		Setting		Description
No.	Superimposed display	No.	Superimposed display	
108	FORMAT SEL	<u>0000</u> 0001 0002	<u>DVCPRO</u> DV DVCAM	<p>These settings are for selecting the format when an L cassette or S cassette is used.</p> <p>0: L cassette → DVCPRO mode S cassette → DV mode</p> <p>1: L cassette/S cassette → DV mode</p> <p>2: L cassette/S cassette → DVCAM mode</p> <p><Notes></p> <p>Bear in mind that, in addition to problems with playback, the trouble described below may occur when a tape which does not match the selected format is inserted.</p> <p>1 If a DV or DVCAM tape is inserted when the DVCPRO mode setting has been selected, the recording operation will be conducted but no guarantee is given for the resulting performance, etc. Conversely, recording is not possible if a DVCPRO cassette tape is inserted when the DV or DVCAM mode setting has been selected.</p> <p>2 The REMAIN display fails to appear properly.</p> <p>3. The slow-down position near the tape start or end is not located accurately.</p> <p>4. When a tape which does not match the selected format is inserted, no guarantee is given for the resulting performance, etc.</p>
112	AUTO REW	<u>0000</u> 0001	<u>OFF</u> ON	<p>This selects whether to rewind the tape automatically to the tape start when the tape end is detected.</p> <p>0: The tape stops at the tape end.</p> <p>1: The tape is rewound to the tape start.</p>
113	MEMORY STOP	<u>0000</u> 0001	<u>OFF</u> ON	<p>This selects whether the VTR is to stop automatically when the counter value reaches "0" during a fast forwarding or rewinding operation in the CTL mode.</p> <p>0: The VTR does not stop.</p> <p>1: The VTR stops automatically.</p> <p><Notes></p> <p>1 The stop mode concerned is either the stop or the still-picture (SHTL STILL) mode depending on the setup menu No. 313 (AFTER CUE-UP) setting.</p> <p>2. When both the AUTO REW function and MEMORY function have been selected at the same time, the AUTO REW function takes precedence.</p>

The underline on the setting item denotes the initial setting.

Memory stop function

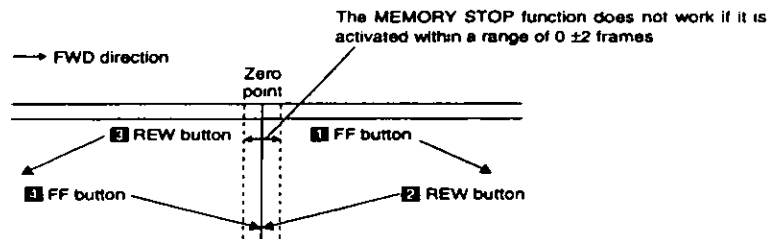

- 1 When the FF button is pressed, the VTR performs the regular fast forward operation since the zero point is not located in the direction of operation.
- 2 When the REW button is pressed, the PREROLL lamp lights (the SHTL lamp lights as well), the VTR proceeds with the preroll operation, and it automatically stops when it reaches the position where the counter reads "0."
- 3 When the REW button is pressed, the VTR performs the regular rewinding operation since the zero point is not located in the direction of operation.
- 4 When the FF button is pressed, the PREROLL lamp lights (the SHTL lamp lights as well), the VTR proceeds with the preroll operation, and it automatically stops when it reaches the position where the counter reads "0."

USER menu

<OPERATION> (continued)

Item		Setting		Description
No.	Superimposed display	No.	Superimposed display	
115	STOP RESPNS	<u>0000</u> 0001	<u>NORMAL</u> QUICK	<p>This selects the response when the mode is changed to STOP/STILL while the tape is traveling.</p> <p>0: Priority is given to the output picture. 1: Priority is given to the response.</p> <p><Notes></p> <ul style="list-style-type: none"> At the 1 (QUICK) setting, the picture may not be as clear in the STOP/STILL mode as it would be at the 0 (NORMAL) setting. CTL may shift by ± 2 frames.
116	EE MODE SEL	<u>0000</u> 0001	<u>NORMAL</u> THRU	<p>This selects the output signals in the EE mode.</p> <p>0: Signals which are delayed by an amount equivalent to the time taken for the internal digital signal processing are output. 1: The signals are output without internal digital signal processing.</p> <p><Notes></p> <ul style="list-style-type: none"> The NORMAL setting is forcibly selected for the internal operation when the editing mode is selected, when SDTI is set as the video input signal selection or when INT SG is selected for the video or audio signals. Use the signals which are output in the EE mode for monitoring purposes.
117	FRZ MODE SEL	<u>0000</u> 0001 0002	<u>DIS</u> STBOFF SOF&EJ	<p>This selects the output pictures from the playback pictures in the STANDBY OFF mode and EJECT mode.</p> <p>0: The video output is muted. 1: The playback picture is frozen at the moment when the STANDBY OFF mode was established, and output. 2: The playback picture is frozen at the moment when the STANDBY OFF mode and EJECT mode were established, and output.</p> <p><Notes></p> <ul style="list-style-type: none"> The status in the freeze mode follows the setting for setup menu No. 608 (FREEZE SEL). In the EJECT mode, freeze pictures are output only when 2 (BLACK) is used as the setup menu No. 105 (AUTO EE SEL) setting.

The underline on the setting item denotes the initial setting.

Setup menus

USER menu

<INTERFACE>

Item		Setting		Description
No.	Superimposed display	No.	Superimposed display	
200	PARA RUN	<u>0000</u> 0001	<u>DIS</u> ENA	This selects whether two or more VTRs are to be operated in synchronization. 0: No operation in synchronization 1: Operation in synchronization <Note> When operating two or more VTRs in synchronization, set item 200 of all the VTRs to 0001.
201	9P SEL	0000 <u>0001</u>	OFF <u>ON</u>	This selects whether the 9P connector functions when the REMOTE/LOCAL switch has been set to REMOTE. 0: Do not function 1: Function
202	ID SEL	<u>0000</u> 0001	<u>OTHER</u> DVCPRO	This selects the ID information which is returned to the controller. 0: 20 25H 1: DVCPRO's, own ID is returned (F0 33H).
203	25P SEL	<u>0000</u> 0001	OFF <u>ON</u>	This selects whether the PARALLEL (25P) connector functions when the REMOTE/LOCAL switch has been set to REMOTE. 0: Does not function 1: Functions
204	RS232C SEL	<u>0000</u> 0001	OFF <u>ON</u>	These settings are for selecting whether the RS-232C connector is to function when the REMOTE/LOCAL switch is set to REMOTE. 0: Connector does not function. 1: Connector functions.
205	BAUD RATE	0000 0001 0002 0003 0004 <u>0005</u>	300 600 1200 2400 4800 <u>9600</u>	These settings are for selecting the RS-232C communication speed (baud rate).
206	DATA LENGTH	0000 <u>0001</u>	7 <u>8</u>	These settings are for selecting the RS-232C data length (Unit: bit)
207	STOP BIT	<u>0000</u> 0001	<u>1</u> 2	These settings are for selecting the RS-232C stop bit length. (Unit: bit)
208	PARITY	<u>0000</u> 0001 0002	<u>NON</u> ODD EVEN	These settings are for selecting the none, odd or even for the RS-232C parity bit. 0: Parity bit is not used. 1: An odd number of bits is used for the parity system 2: An even number of bits is used for the parity system
209	RETURN ACK	0000 <u>0001</u>	OFF <u>ON</u>	These settings are for selecting whether the ACK code is to be returned when a command is received from RS-232C. 0: ACK code is not returned 1: ACK code is returned.
210	25P STBY CMD	<u>0000</u> 0001	<u>OFF/ON</u> ON	This selects the method used to detect the STANDBY COMMAND signal input at the PARALLEL (25P) connector 0: Each time active signals are detected, the STANDBY ON or STANDBY OFF mode is selected alternately. 1: When active signals are detected in the STANDBY OFF mode, the unit is transferred to the STANDBY ON mode. No effect is exerted on operation while the STANDBY ON mode is established.

The underline on the setting item denotes the initial setting.

USER menu

<EDIT>

Item		Setting		Description
No.	Superimposed display	No.	Superimposed display	
301	IN/OUT DEL	<u>0000</u> 0001	<u>MANU</u> <u>AUTO</u>	This selects the operation to be performed when an edit point has been set incorrectly (when the OUT point is before the IN point). 0: Editing is not executed unless the illegal edit point is cleared or set again properly. 1: The edit points already input are automatically cleared.
302	NEGA FLASH	<u>0000</u> 0001	<u>OFF</u> <u>ON</u>	This selects whether to show a negative display when the IN point is greater than the OUT point. 0: No negative display. 1: Negative display.
303	STD/ NON-STD	<u>0000</u> 0001 0002	<u>AUTO</u> <u>STD</u> <u>N-STD</u>	This selects STD or NON-STD in accordance with the composite input signal. 0: Standard/non-standard signals are automatically identified and processed. 1: Standard signals are processed. (Forced STD) 2: Non-standard signals are processed. (Forced NON-STD)
304	SERVO REF	<u>0000</u> 0001	<u>AUTO</u> <u>EXT</u>	This selects the video signal processing. 0: Servo is synchronized with the input signal during recording and editing, or with the REF signal during playback. 1: Servo is synchronized at all times with the REF signal.
305	EDIT RPLCE1	<u>0000</u> <u>0001</u> 0002 0003	<u>N-DEF</u> <u>CH1</u> <u>CH2</u> <u>CH1+2</u>	This sets the channel assignments for the controller's analog audio preset when editing the digital audio of the VTR using a controller which does not have a digital audio edit preset control function. This selects the channel concerned when the VTR CH1 edit preset is set in compliance with the ON or OFF presetting for the analog audio signals designated by the controller. 0: Not set. 1: Compliance with analog CH1 edit preset. 2: Compliance with analog CH2 edit preset. 3: Compliance with either analog CH1 or CH2 edit preset.
306	EDIT RPLCE2	<u>0000</u> 0001 <u>0002</u> 0003	<u>N-DEF</u> <u>CH1</u> <u>CH2</u> <u>CH1+2</u>	This selects the channel concerned when the VTR CH2 edit preset is set in compliance with the ON or OFF presetting for the analog audio signals designated by the controller. 0: Not set. 1: Compliance with analog CH1 edit preset. 2: Compliance with analog CH2 edit preset. 3: Compliance with either analog CH1 or CH2 edit preset.
307	EDIT RPLCEC	<u>0000</u> 0001 0002 0003	<u>N-DEF</u> <u>CH1</u> <u>CH2</u> <u>CH1+2</u>	This selects the channel concerned when the VTR CUE edit preset is set in compliance with the ON or OFF presetting for the analog audio signals designated by the editor or controller. 0: Not set. 1: Compliance with analog CH1 edit preset. 2: Compliance with analog CH2 edit preset. 3: Compliance with either analog CH1 or CH2 edit preset.

The underline on the setting item denotes the initial setting.

Setup menus

USER menu

<EDIT> (continued)

Item		Setting		Description
No.	Superimposed display	No.	Superimposed display	
308	CONFI EDIT	<u>0000</u> 0001	___OFF ___ON	This selects whether to conduct simultaneous playback while editing is in progress. 0: No simultaneous playback 1: Simultaneous playback <Note> Simultaneous playback is valid when the TAPE/EE switch is set to TAPE.
309	AUD EDIT IN	0000 <u>0001</u>	___CUT ___FADE	This selects the connection method for the digital audio edit IN point. 0: Cut processing 1: V Fade processing
310	AUD EDIT OUT	0000 <u>0001</u>	___CUT ___FADE	This selects the connection method for the digital audio edit OUT point. 0: Cut processing 1: V Fade processing
311	AUTO ENTRY	<u>0000</u> 0001	___DIS ___ENA	This selects whether the IN point is to be entered using the PREROLL button when it has not been entered. 0: IN point is not entered. 1: IN point is entered.
312	CF ADJ SEL	<u>0000</u> 0001	___PLAYER ___RECORD	This selects the CF adjustment deck with deck-to-deck editing. 0: The player's edit IN/OUT points are adjusted. (reference as the RECORDER side) 1: The recorder's edit IN/OUT points are adjusted. (reference as the PLAYER side)
313	AFTER CUE-UP	<u>0000</u> 0001	___STOP ___STILL	This selects the mode after cue-up operation is complete. 0: STOP mode 1: SHTL STILL mode
316	VAR STEP	<u>0000</u> 0001	___FINE ___COARSE	This selects the VAR speed during remote control operations. 0: The tape is played at the fine step speed. 1: The tape is played at a speed at which noise-less playback is possible in the $-0.43\times$ to $+1\times$ ($-0.5\times$ to $+1\times$) range. <Notes> • The tape will be played at the speed given in parentheses in the DV/DVCAM mode. • At the 1 (COARSE) setting, the phase cannot be synchronized from the editing controller.
317	VAR FWD MAX	<u>0000</u> 0001 0002 0003 0004 0005 0006 0007 0008	___+4.1 ___+1.85 ___+1 ___+0.75 ___+0.5 ___+0.3 ___+0.2 ___+0.1 ___+0.03	This sets the maximum VAR FWD speed. 0: $+4.1\times$ ($+3.1\times$) speed 1: $+1.85\times$ ($+1.85\times$) speed 2: $+1\times$ ($+1\times$) speed 3: $+0.75\times$ ($+0.5\times$) speed 4: $+0.5\times$ ($+0.5\times$) speed 5: $+0.3\times$ ($+0.3\times$) speed 6: $+0.2\times$ ($+0.2\times$) speed 7: $+0.1\times$ ($+0.1\times$) speed 8: $+0.03\times$ ($+0.03\times$) speed <Notes> • The tape will be played at the speed given in parentheses in the DV/DVCAM mode. • In the DV/DVCAM mode, the maximum speed is set to $+1\times$ when the dial on the front panel is operated. • At any speed setting other than 0 ($+4.1$), the phase cannot be synchronized from the editing controller.

The underline on the setting item denotes the initial setting.

USER menu

<EDIT> (continued)

Item		Setting		Description
No.	Superimposed display	No.	Superimposed display	
318	VAR REV MAX	<u>0000</u>	<u>-4.1</u>	<p>This sets the maximum VAR REV speed.</p> <p>0: -4.1x (-3.1x) speed 1: -1.85x (-1.85x) speed 2: -1x (-1x) speed 3: -0.43x (-0.5x) speed 4: -0.3x (-0.3x) speed 5: -0.2x (-0.2x) speed 6: -0.1x (-0.1x) speed 7: -0.03x (-0.03x) speed</p> <p><Notes></p> <ul style="list-style-type: none"> The tape will be played at the speed given in parentheses in the DV/DVCAM mode. In the DV/DVCAM mode, the maximum speed is set to -0.5x when the dial on the front panel is operated.
		0001	-1.85	
		0002	-1	
		0003	-0.43	
		0004	-0.3	
		0005	-0.2	
		0006	-0.1	
		0007	-0.03	
319	JOG STEP	<u>0000</u>	<u>FINE</u>	<p>This selects the JOG speed during remote control operations</p> <p>0: The tape is played at the fine step speed. 1: The tape is played at a speed at which noise-less playback is possible in the -0.43x to +1x (-0.5x to +1x) range.</p> <p><Notes></p> <ul style="list-style-type: none"> The tape will be played at the speed given in parentheses in the DV/DVCAM mode. At the 1 (COARSE) setting, the phase cannot be synchronized from an editing controller which synchronizes the phase using the JOG command.
		<u>0001</u>	<u>COARSE</u>	
320	JOG FWD MAX	<u>0000</u>	<u>+4.1</u>	<p>This sets the maximum JOG FWD speed.</p> <p>0: +4.1x (+3.1x) speed 1: +1.85x (+1.85x) speed 2: +1x (+1x) speed</p> <p><Notes></p> <ul style="list-style-type: none"> The tape will be played at the speed given in parentheses in the DV/DVCAM mode. The maximum speed is set to +1x when the dial on the front panel is operated. At any speed setting other than 0 (+4.1), the phase cannot be synchronized from an editing controller which synchronizes the phase using the JOG command.
		0001	+1.85	
		<u>0002</u>	<u>+1</u>	
321	JOG REV MAX	<u>0000</u>	<u>-4.1</u>	<p>This sets the maximum JOG REV speed.</p> <p>0: -4.1x (-3.1x) speed 1: -1.85x (-1.85x) speed 2: -1x (-1x) speed 3: -0.43x (-0.5x) speed</p> <p><Notes></p> <ul style="list-style-type: none"> The tape will be played at the speed given in parentheses in the DV/DVCAM mode. When the dial on the front panel is operated, the maximum speed is set to -1x in the DVCPRO mode and to -0.5x in the DV/DVCAM mode.
		0001	-1.85	
		0002	-1	
		<u>0003</u>	<u>-0.43</u>	

The underline on the setting item denotes the initial setting.

Setup menus

USER menu

<EDIT> (continued)

Item		Setting		Description
No.	Superimposed display	No.	Superimposed display	
322	AUD MEM MODE	<u>0000</u> 0001 0002 0003 0004	OFF AMU_X AMU_VO INT_X INT_VO	<p>This selects whether the voice-over or audio cross channel editing which is to be performed using the AJ-YA752 audio memory unit or internal audio memory.</p> <p>0: Neither voice-over nor audio cross channel editing is performed</p> <p>1: Audio cross channel editing is performed using the AJ-YA752 audio memory unit.</p> <p>2: Voice-over editing is performed using the AJ-YA752 audio memory unit.</p> <p>3: Audio cross channel editing is performed using the internal audio memory.</p> <p>4: Voice-over editing is performed using the internal audio memory.</p> <p><Notes></p> <ul style="list-style-type: none"> The RS-232C interface will not function with the 1 (AMU_X) or 2 (AMU_VO) setting. Refer to the instruction manual of the AJ-YA752 audio memory unit for details on how to use each mode using this unit.
323	AUD MEM CH	0000 <u>0001</u>	CH1 CH2	<p>This sets the channel for the voice-over or audio cross channel editing which is performed using the AJ-YA752 audio memory unit or internal audio memory.</p> <p>0: The signals are recorded onto CH1.</p> <p>1: The signals are recorded onto CH2.</p> <p><Note></p> <p>This setting has no effect when AMU_VO has been selected as the setup menu No. 322 (AUD MEM MODE) setting.</p>
324	POSTROLL TM	0000 0001 <u>0002</u> 0003 0004 0005	0s 1s 2s 3s 4s 5s	<p>This sets the postroll time.</p> <p>Any time from 0 to 5 seconds can be set in 1-second units.</p>

The underline on the setting item denotes the initial setting.

USER menu

<TAPE PROTECT>

Item		Setting		Description
No.	Superimposed display	No.	Superimposed display	
400	STILL TIMER	0000	0.5s	This selects the time to be taken until the unit goes into the tape protection mode when it is left standing in the stop or search still (JOG/VAR/SHTL) mode. (Unit: s = second, min = minute) <Note> With the DV or DVCAM format, the maximum time which can be set is 10 s even when a setting above 10 s has been selected. The selection screen, however, will operate for up to 2 minutes.
		0001	5s	
		0002	10s	
		0003	20s	
		0004	30s	
		0005	40s	
		0006	50s	
		0007	1min	
		<u>0008</u>	<u>2min</u>	
401	SRC PROTECT	<u>0000</u>	<u>STEP</u>	This selects the operation during the tape protection mode when the unit is left standing in the still status during the search mode (JOG/VAR/SHTL). 0: STEP FWD. 1: HALF LOADING. <Note> When STEP FWD is selected, the unit automatically goes into the HALF LOADING mode when the total time for which the unit is left standing in the still status reaches 30 minutes (DVCPR) or 1 minute (DV or DVCAM).
		0001	HALF	
402	DRUM STDBY	0000	OFF	This selects the drum operation in the STANDBY OFF mode. 0: The drum stops rotating. 1: The drum continues rotating.
		<u>0001</u>	<u>ON</u>	
403	STOP PROTECT	0000	STEP	This selects the operation in the tape protection mode when the unit has been left standing in the STOP mode. 0: STEP FWD 1: HALF LOADING <Note> When STEP FWD is selected, the unit is automatically transferred to the HALF LOADING mode when the total time during which it has been left standing in the STOP mode reaches 30 minutes (or 1 minute with a DV/DVCAM tape).
		<u>0001</u>	<u>HALF</u>	

The underline on the setting item denotes the initial setting.

<Note>

In order to protect the tape and VTR helical heads, it is recommended that the Still Timer be set for automatic tape protection mode in 30 seconds or under.

<TIME CODE>

Item		Setting		Description
No.	Superimposed display	No.	Superimposed display	
500	VITC POS-1	0000	10L	This sets the position where the VITC signal is to be inserted. (The same line as for VITC POS-2 in 501 cannot be selected)
		0001	11L	
		0002	12L	
		0003	13L	
		0004	14L	
		0005	15L	
		<u>0006</u>	<u>16L</u>	
		0007	17L	
		0008	18L	
		0009	19L	
		0010	20L	

The underline on the setting item denotes the initial setting.

AJ-D850P

Setup menus

USER menu

<TIME CODE>

Item		Setting		Description
No.	Superimposed display	No.	Superimposed display	
501	VITC POS-2	0000 0001 0002 0003 0004 0005 0006 0007 <u>0008</u> 0009 0010	10L 11L 12L 13L 14L 15L 16L 17L 18L 19L 20L	This sets the position where the VITC signal is to be inserted. (The same line as for VITC POS-1 in 500 cannot be selected.)
502	VITC BLANK	0000 <u>0001</u>	BLANK THRU	This selects whether to output the VITC data to the positions selected by VITC POS-1 in 500 and VITC POS-2 in 501. 0: Data is not output. 1: Data is output.
503	TCG REGEN	<u>0000</u> 0001 0002	<u>TC&UB</u> TC UB	This selects the signal to be regenerated when the time code generator (TCG) in the REGEN mode. 0: Both the time code and user bit are regenerated 1: Only the time code is regenerated. 2: Only the user bit is regenerated.
504	REGEN MODE	<u>0000</u> 0001 0002 0003	<u>AS&IN</u> ASSEM INSRT SW	This selects whether the time code is to be regenerated during automatic editing using the unit's control panel. 0: Time code is regenerated with assemble or insert editing 1: Time code is regenerated with assemble editing 2: Time code is regenerated with insert editing 3: Setting complies with REGEN/PRESET switch setting.
505	EXT TC SEL	<u>0000</u> 0001	<u>LTC</u> VITC	This selects the time code to be used when an external time code is to be used. 0: The LTC of the TIME CODE IN connector is used. 1: The video signal VITC is used.
506	BINARY GP	<u>0000</u> 0001 0002 0003 0004 0005 0006 0007	<u>000</u> 001 010 011 100 101 110 111	This sets the usage status of the user bit of the time code generated by the TCG. 0: NOT SPECIFIED (character set not specified) 1: ISO CHARACTER (8 bits character set based on ISO646, ISO2022) 2: UNASSIGNED 1 (undefined) 3: UNASSIGNED 2 (undefined) 4: UNASSIGNED 3 (undefined) 5: PAGE/LINE 6: UNASSIGNED 4 (undefined) 7: UNASSIGNED 5 (undefined)
507	PHASE CORR	<u>0000</u> 0001	<u>OFF</u> ON	This selects whether to control the phase correction of the LTC generated by the TCG. 0: Phase correction control is not performed. 1: Phase correction control is performed.
508	TCG CF FLAG	<u>0000</u> 0001	<u>OFF</u> ON	This selects whether the CF flag of the TCG is to ON. 0: CF flag is OFF 1: CF flag is ON.
509	DF MODE	<u>0000</u> 0001	<u>DF</u> NDF	This selects the DF/NDF mode for CTL and TCG 0: Drop frame mode. 1: Non-drop frame mode No. 509 is valid when the CONTROL is LOCAL or LOCAL ENA of item 004 to "ENA"

The underline on the setting item denotes the initial setting.

AJ-D850E

USER menu

<TIME CODE> (continued)

Item		Setting		Description
No.	Superimposed display	No.	Superimposed display	
511	TC OUT REF	<u>0000</u> 0001	<u>V OUT</u> TC_IN	This is used to switch the phase of the time code, which is output from the TIME CODE OUT connector, for the external LTC input when the TC INT/EXT switch is at the EXT position (In EE mode only) 0: Time code is synchronized with output video signal. 1: Time code is synchronized with external time code input.
512	VITC OUT	<u>0000</u> 0001	<u>SBC</u> VAUX	This selects how the VITC which is to be superimposed onto the output video signal is to be output. 0: During recording: The input time code, which was selected by the setup menu No. 505 (EXT TC SEL) setting and TC INT/EXT switch, is output as the VITC. During playback: The time code recorded in the SBC area is output as the VITC. 1: During recording: The time code detected from the input video signal is output as the VITC. During playback: The time code recorded in the VAUX area is output as the VITC. <Note> The time code detected from the input video signal is automatically recorded in the VAUX area while pictures are being recorded.

The underline on the setting item denotes the initial setting.

<VIDEO>

Item		Setting		Description
No.	Superimposed display	No.	Superimposed display	
600	Pb/Pr IN LV	0000 <u>0001</u>	MII <u>B-CAM</u>	This selects the component input signal level. 0: MII level. 1: B cam level.
601	INT BB SIG	<u>0000</u> 0001	<u>OFF</u> BB	This selects whether to generate the internal black burst signal. 0: Signal is not generated. 1: Signal is generated.
602	INPUT C KILL	0000 <u>0001</u>	B/W <u>AUTO</u>	This selects color killer processing for the video input signals. 0: The signals are forcibly processed as B/W signals. 1: The signals are automatically processed
603	OUT VSYNC	<u>0000</u> 0001	<u>N-VF</u> VF	This selects whether to float the vertical sync position of the video output in order to align the video output phase with the input in the EE/record/edit modes. 0: Signals are not floated. 1: Signals are floated.

The underline on the setting item denotes the initial setting.

SBC (sub code data) area:

This area is separate from the video and audio data area on the helical track. The time codes complying with SMPTE/EBU standards, recording dates and times, and other tape control information are stored here. As with the conventional LTC (linear time code), the time code can be read even during rewinding or fast forwarding. It can also be read out when the tape has stopped.

VAUX (video auxiliary data) area:

This area is to be found in the video data area on the helical track. The additional information relating to the video data is stored here.

AJ-D850E

Setup menus

USER menu

<VIDEO> (continued)

Item		Setting		Description
No.	Superimposed display	No.	Superimposed display	
604	V-MUTE SEL	<u>0000</u> 0001	N-MUTE <u>LOW RE</u>	This selects whether the video output signals are to be muted when the blank portion of the tape is detected during playback. 0: No muting. (Freeze) 1: Muting. (Set to gray.)
605	CC (F1) BLANK	<u>0000</u> 0001	BLANK <u>THRU</u>	This selects ON or OFF for the closed capture signal in the first field. 0: Forced blanking performed. 1: Blanking not performed
606	CC (F2) BLANK	<u>0000</u> 0001	BLANK <u>THRU</u>	This selects ON or OFF for the closed capture signal in the second field. 0: Forced blanking performed. 1: Blanking not performed.
608	FREEZE SEL	<u>0000</u> 0001	<u>FIELD</u> FRAME	This selects the freeze mode for still pictures 0: Field freeze 1: Frame freeze. <Note> When frame freeze has been selected, the frame slow status is established with the slow setting.
610	OUT C KILL	<u>0000</u> 0001	B/W <u>COLOR</u>	This selects chroma color killer processing for the video output signals. 0: The signals are forcibly processed as B/W signals. 1: The signals are automatically processed.
611	EDH	<u>0000</u> 0001	OFF <u>ON</u>	This selects whether to superimpose EDH onto the serial output signals. 0: EDH is not superimposed. 1: EDH is superimposed. <Note> This item is valid when the optional serial interface board has been installed.
613	VIN SETUP	<u>0000</u> 0001	<u>THRU</u> CUT	This selects whether the composite signal is to be recorded with setup or without setup. 0: When recording signals with no setup 1: When recording signals with 7.5% setup. <Note> When recording composite signals, be sure to double-check whether the signals are to be recorded with or without setup.
614	VOUT SETUP	<u>0000</u> 0001	<u>THRU</u> ADD	This selects the composite output signal 0: The signal is output without setup. 1: The signal is output with 7.5% setup. <Note> When setting this menu item, bear the setup menu No. 616 (CMPNT SETUP) setting in mind
616	CMPNT SETUP	<u>0000</u> 0001	<u>THRU</u> CUT	When composite, component and serial (digital) signals are to be output: 0: They are output in their original form. 1: They are output without the 7.5% setup signal.
617	INTER- POLATE	<u>0000</u> 0001	OFF <u>AUTO</u>	Although vertical interpolation is performed automatically during slow-motion playback and the vertical motion of the playback picture is reduced, this menu item enables the interpolation operation to be forcibly turned off. 0: The interpolation operation is forcibly turned off. 1: The interpolation operation is automatically turned on during slow-motion playback.

The underline on the setting item denotes the initial setting.

AJ-D850E

USER menu

<AUDIO>

Item		Setting		Description
No.	Superimposed display	No.	Superimposed display	
700	CH1 IN LV	0000 <u>0001</u> 0002	4dB <u>0dB</u> -20 dB	This selects the audio input (CH1) reference level switching.
701	CH2 IN LV	0000 <u>0001</u> 0002	4dB <u>0dB</u> -20 dB	This selects the audio input (CH2) reference level switching.
702	CUE IN LV	0000 <u>0001</u> 0002 0003	4dB <u>0dB</u> -20 dB -60 dB	This selects the CUE input reference level switching.
703	CH1 OUT LV	0000 <u>0001</u> 0002	4dB <u>0dB</u> -20 dB	This selects the audio output (CH1) reference level switching.
704	CH2 OUT LV	0000 <u>0001</u> 0002	4dB <u>0dB</u> -20 dB	This selects the audio output (CH2) reference level switching.
705	CUE OUT LV	0000 <u>0001</u> 0002	4dB <u>0dB</u> -20 dB	This selects the CUE output reference level switching.
706	MONIL OUT LV	0000 <u>0001</u> 0002	4dB <u>0dB</u> -20 dB	This selects the audio monitor output (Lch) reference level switching.
707	MONIR OUT LV	0000 <u>0001</u> 0002	4dB <u>0dB</u> -20 dB	This selects the audio monitor output (Rch) reference level switching.
708	MONI OUT	0000 <u>0001</u>	UNITY <u>VAR</u>	This selects the audio monitor output volume UNITY/ VARIABLE reference switching. 0: The volume is output at the preset value. 1: The volume is linked with the headphones volume control.
709	EMPHASIS	<u>0000</u> 0001	<u>OFF</u> ON	This sets the emphasis ON or OFF.
710	CH1 IN SEL	<u>0000</u> 0001	<u>ANA</u> DIGI	This selects the CH1 input when USER SET has been selected by pressing the unit's AUDIO input selector switch. 0: Analog input. 1: Digital input.
711	CH2 IN SEL	<u>0000</u> 0001	<u>ANA</u> DIGI	This selects the CH2 input when USER SET has been selected by pressing the unit's AUDIO input selector switch. 0: Analog input. 1: Digital input.
712	DIGI IN SEL	<u>0000</u> 0001 0002	<u>AES</u> SIF1_2 SIF3_4	This selects the CH1 and CH2 digital input when USER SET has been selected by the unit's AUDIO input selector switch. 0: AES. 1: Serial I/F 1 and 2. 2: Serial I/F 3 and 4. <Note> Selections 1 and 2 are selected when the serial option is mounted.

The underline on the setting item denotes the initial setting.

AJ-D850E

Setup menus

USER menu

<AUDIO> (continued)

Item		Setting		Description
No.	Superimposed display	No.	Superimposed display	
713	MONI CH SEL	<u>0000</u> 0001 0002	<u>MANU</u> AUTO1 AUTO2	This selects the monitor output. 0: The output is as selected in MONITOR SELECT 1: The output defaults to CUE except when speed factor is between -0.43x and 1x, inclusive, in which case output is PCM AUDIO. 2: The output defaults to CUE except in PLAY mode, in which case output is PCM AUDIO. <Note> These menu settings are valid when CH1 or CH2 has been selected by the MONITOR SELECT L/R switches on the front panel. (When CUE has been selected, the CUE signal will be output at all speeds regardless of the above menu setting.)
714	REC CH1	<u>0000</u> 0001 0002	<u>CH1</u> CH2 CH1+2	This selects the input signal to be recorded on the audio CH1 track. 0: Audio input CH1 signal. 1: Audio input CH2 signal. 2: Mixed audio input CH1 and CH2 signal.
715	REC CH2	<u>0000</u> <u>0001</u> 0002	CH1 <u>CH2</u> CH1+2	This selects the input signal to be recorded on the audio CH2 track 0: Audio input CH1 signal. 1: Audio input CH2 signal. 2: Mixed audio input CH1 and CH2 signal.
716	REC CUE	<u>0000</u> 0001 0002 0003	<u>CUE</u> CH1 CH2 CH1+2	This selects the input signal recorded in CUE. 0: CUE input 1: The signal selected in Setup Menu No. 714 is recorded. 2: The signal selected in Setup Menu No. 715 is recorded. 3: A mixed signal of the signals selected in Setup Menu No. 714 and Setup Menu No. 715 is recorded.
718	DV OUTPUT	<u>0000</u> 0001 0002	<u>ST1</u> ST2 ST1+2	This selects the AUDIO CH1 and CH2 output signals during DV or DVCAM format playback. 0: The CH1 track signals are output to CH1 and the CH2 track signals to CH2. 1: The CH3 track signals are output to CH1 and the CH4 track signals to CH2. 2: The mixed CH1 and CH3 track signals are output to CH1 and the mixed CH2 and CH4 track signals to CH2. <Note> This item setting is valid only when the tape recorded on the four channels of the DV or DVCAM format is played back.
719	PB FADE	<u>0000</u> 0001 0002	<u>AUTO</u> CUT FADE	This selects the processing method for the audio edit points (IN point, OUT point) during playback. 0: According to the status during recording 1: Forced CUT 2: Forced FADE
720	EMBEDDED AUD	<u>0000</u> <u>0001</u>	OFF <u>ON</u>	This selects whether to superimpose the audio data onto the serial output. 0: Data is not superimposed. 1: Data is superimposed. <Note> This item is valid when the optional serial interface board has been installed.
722	INT SG	<u>0000</u> 0001	OFF <u>ON</u>	This selects whether to use the internal signals as the audio input signals 0: The internal signals are not selected 1: The internal signals are selected <Note> The internal signals have a frequency of 1 kHz

The underline on the setting item denotes the initial setting.

USER menu

<AUDIO> (continued)

Item		Setting		Description
No.	Superimposed display	No.	Superimposed display	
723	DV PB ATT	<u>0000</u> 0001	<u>OFF</u> ON	This selects the audio output level for DV or DVCAM format playback. 0: The audio output level is not attenuated. 1: The audio output level is attenuated (reduced). <Notes> As indicated below, whether the setting takes effect or not depends on the size of the cassette tape used. 1. When an "L" size cassette is used The setting takes effect only when "DV" or "DVCAM" has been selected as the setting for setup menu No. 108 (FORMAT SEL). 2. When an "M" size cassette is used The setting does not take effect. 3. When an "S" size cassette is used The setting takes effect.
724	MONI SEL INH	<u>0000</u> 0001	<u>OFF</u> ON	This selects whether to allow (enable) or prohibit (disable) the operation of the MONITOR SELECT and MONITOR SET buttons on the front panel. 0: The buttons can be operated. 1: Operation of the buttons is prohibited.
725	CUE SLOW	<u>0000</u> 0001	<u>STEP</u> LINEAR	This selects the tape travel status (CUE track playback status) during SLOW playback. 0: Priority is given to the output picture, and tape travel is set to the step feed status. 1: Priority is given to CUE track playback, and the tape travel is set to the linear status. <Notes> When "1" (LINEAR) has been set: • It may not be possible to achieve as clear a picture as in the STEP mode. • The CTL counter may not operate properly.
726	CUE OUT	<u>0000</u> 0001	<u>NORMAL</u> DIRECT	This selects the output signals from the CUE OUT connector. 0: The timing is aligned with the output picture. 1: The signals recorded on the tape are output with no delay <Note> When "1" (DIRECT) has been set, the output picture and CUE output timing will differ.
727	MONI MIX L	<u>0000</u> 0001	<u>OFF</u> CH1+2	This enables mixed signals to be selected for the monitoring through the headphones. 0: The signals are not mixed. 1: The CH1 and CH2 signals are mixed and output to the left channel.
728	MONI MIX R	<u>0000</u> 0001	<u>OFF</u> CH1+2	This enables mixed signals to be selected for the monitoring through the headphones. 0: The signals are not mixed. 1: The CH1 and CH2 signals are mixed and output to the right channel.
729	REC PT MUTE	<u>0000</u> 0001	<u>OFF</u> ON	This selects whether to mute the sound at the joins in the recording during playback in the DV or DVCAM format. 0: The sound is not muted. 1: The sound is muted.
730	CUE OUT SEL	<u>0000</u> 0001	<u>OFF</u> ON	This selects whether the cue signal is to be output to the main line system output in the search mode. 0: The cue signal is not output. 1: The cue signal is output. (This applies only when a setting other than MANU has been selected for setup menu item No. 713 (MONI CH SEL).)

The underline on the setting item denotes the initial setting.

AJ-D850P

Setup menus

USER menu

<V BLANK>

Item		Setting		Description
No.	Superimposed display	No.	Superimposed display	
800	ADD LINE	0000	OFF	This selects the mode in which the input signals are recorded on additional lines. 0: No additional line recording. 1: For 1-line recording of the input signals in the 422 mode 2: For 1-line recording of the input signals in the 411 mode 3: For the 1-line recording of input signals in their original form as the luminance signal. 4: For the 1-line recording of only the luminance signal after the input signals have been separated into the luminance and chrominance signals. 5: For the 1-line recording of only the chrominance signal after the input signals have been separated into the luminance and chrominance signals. 6: For the 2-line recording of input signals in their original form as the luminance signal. 7: For the 2-line recording of only the luminance signal after the input signals have been separated into the luminance and chrominance signals. 8: For the 2-line recording of only the chrominance signal after the input signals have been separated into the luminance and chrominance signals. <Notes> • When a setting from 1 to 8 is selected and the STOP button is pressed, operation moves to the sub screen and the recording line or lines can be selected. Press the STOP button again to return from the sub screen. • Depending on the additional line recording mode, the number of lines for recording teletext will differ
		0001	YC422	
		<u>0002</u>	YC411	
		0003	Y1_B/W	
		0004	Y1_BPF	
		0005	C1	
		0006	Y2_B/W	
		0007	Y2_BPF	
		0008	C2	
Sub screen				
00	REC LINE	0000	10L	For selecting the additional line where the signals are to be recorded.
		⋮	⋮	
		0012	22L	
		0013	263L	
		0014	273L	
		⋮	⋮	
		<u>0025</u>	284L	
0026	525L			
01	REC LINE2	0000	10L	For selecting the additional line where the signals are to be recorded. <Note> This menu item is not displayed when a setting from 1 to 5 has been selected as the additional line mode.
		⋮	⋮	
		0012	22L	
		0013	263L	
		0014	273L	
		⋮	⋮	
		<u>0016</u>	275L	
0025	284L			
0026	525L			

The underline on the setting item denotes the initial setting.

USER menu

<V BLANK> (continued)

Item		Setting		Description
No.	Superimposed display	No.	Superimposed display	
802	TELETEXT SEL	<u>0000</u> 0001	<u>MOJI</u> NABTS	For selecting the type of teletext signals to be recorded 0: MOJI system 1: NABTS system
803	TELETEXT DET	<u>0000</u> 0001 0002	<u>OFF</u> AUTO MANU	This selects the method used to detect the lines in which the teletext signals are to be recorded 0: The teletext signals are not recorded. 1: The teletext signals are automatically detected and recorded. 2: The lines in which the teletext signals are to be recorded are selected and set. <Notes> • When setting "1 (AUTO)" is selected, it may not be possible to record the teletext signals in all the lines depending on the setting of setup menu item No. 800 (ADD LINE). • When setting "2 (MANU)" is selected and the STOP button is pressed, operation transfers to the sub-screen, and the number of recording lines can be selected To return from the sub-screen, press the STOP button again • The number of lines in which the teletext signals can be recorded depends on the setting of setup menu item No 800 (ADD LINE).
Sub screen				
00	REC LINE1	<u>0000</u> 0001 0002 0003 0004 0005 0006 0007 0008 0009 0010 0011 0012 12	<u>OFF</u> 10&273 11&274 12&275 13&276 14&277 15&278 16&279 17&280 18&281 19&282 20&283 21&284 22	This selects the lines in which the teletext signals are to be recorded. Factory mode settings REC LINE1: OFF REC LINE2: OFF REC LINE3: OFF REC LINE4: OFF REC LINE5: OFF REC LINE6: OFF REC LINE7: OFF REC LINE8: OFF REC LINE9: OFF REC LINE10: OFF REC LINE11: OFF REC LINE12: OFF REC LINE13: OFF
804	BLANK LINE	<u>0000</u> 0001 0002	<u>BLANK</u> THRU MANU	This selects blanking ON or OFF for the vertical blanking period of the video signals. 0: Blanking is effected forcibly for all lines. 1: No blanking is effected for any of the lines. 2: Blanking ON or OFF is selected for each line. <Note> When setting "2 (MANU)" is selected and the STOP button is pressed, operation transfers to the sub-screen, and ON or OFF can be selected for each line. To return from the sub-screen, press the STOP button again.

The underline on the setting item denotes the initial setting.

AJ-D850P

Setup menus

USER menu

<V BLANK> (continued)

Item		Setting		Description
No.	Superimposed display	No.	Superimposed display	
Sub screen				
00	LINE 10&273	<u>0000</u> 0001	<u>BLANK</u> THRU	0: Blanking is forcibly effected. 1: No blanking is effected
01	LINE 11&274	<u>0000</u> 0001	<u>BLANK</u> THRU	0: Blanking is forcibly effected 1: No blanking is effected.
02	LINE 12&275	<u>0000</u> 0001	<u>BLANK</u> THRU	0: Blanking is forcibly effected. 1: No blanking is effected.
03	LINE 13&276	<u>0000</u> 0001	<u>BLANK</u> THRU	0: Blanking is forcibly effected. 1: No blanking is effected.
04	LINE 14&277	<u>0000</u> 0001	<u>BLANK</u> THRU	0: Blanking is forcibly effected. 1: No blanking is effected.
05	LINE 15&278	<u>0000</u> 0001	<u>BLANK</u> THRU	0: Blanking is forcibly effected. 1: No blanking is effected.
06	LINE 16&279	<u>0000</u> 0001	<u>BLANK</u> THRU	0: Blanking is forcibly effected. 1: No blanking is effected.
07	LINE 17&280	<u>0000</u> 0001	<u>BLANK</u> THRU	0: Blanking is forcibly effected. 1: No blanking is effected.
08	LINE 18&281	<u>0000</u> 0001	<u>BLANK</u> THRU	0: Blanking is forcibly effected. 1: No blanking is effected
09	LINE 19&282	<u>0000</u> 0001	<u>BLANK</u> THRU	0: Blanking is forcibly effected. 1: No blanking is effected
10	LINE 20&283	<u>0000</u> 0001	<u>BLANK</u> THRU	0: Blanking is forcibly effected. 1: No blanking is effected.
11	LINE 21&284	<u>0000</u> 0001	<u>BLANK</u> THRU	0: Blanking is forcibly effected. 1: No blanking is effected.

The underline on the setting item denotes the initial setting.

USER menu

<MENU>

Item		Setting		Description
No.	Superimposed display	No.	Superimposed display	
A00	LOAD	<u>0000</u> 0001 0002 0003	<u>USER2</u> USER3 USER4 USER5	This selects the user file whose contents will be loaded into USER1 0: The USER2 file contents are loaded. 1: The USER3 file contents are loaded. 2: The USER4 file contents are loaded. 3: The USER5 file contents are loaded. <Note> When the SET button is pressed after loading, the setting will be stored in the memory. When the MENU button is pressed, the setting will not be changed.
A01	SAVE	<u>0000</u> 0001 0002 0003 0004	<u>USER2</u> USER3 USER4 USER5 LOCKED	This selects the user file into which the USER1 settings will be saved. 0: The settings are saved in USER2. 1: The settings are saved in USER3. 2: The settings are saved in USER4. 3: The settings are saved in USER5. 4: This display appears when all the user files are in the change prohibit status <Notes> • User files whose status have been set to change prohibit cannot be selected • When all the user files are in the change prohibit status, the "LOCKED" display appears and the contents cannot be saved.
A02	P.ON LOAD	<u>0000</u> 0001 0002 0003 0004	<u>OFF</u> USER2 USER3 USER4 USER5	This loads the contents of the selected user file into USER1 and it starts operation with the USER1 settings when the power is turned on. 0: Operation is started with the settings of the previously set user file. 1: The contents of USER2 are loaded into USER1 and operation is started with the USER1 settings 2: The contents of USER3 are loaded into USER1 and operation is started with the USER1 settings 3: The contents of USER4 are loaded into USER1 and operation is started with the USER1 settings 4: The contents of USER5 are loaded into USER1 and operation is started with the USER1 settings
A03	MENU LOCK	<u>0000</u> 0001	<u>OFF</u> ON	This selects whether to set or release the user file (USER2 – USER5) lock mode. 0: The lock is released (changes can be made) 1: The lock is set (changes are prohibited) <Note> The lock cannot be set for USER1.

The underline on the setting item denotes the initial setting.

<Notes>

- No. A00 (LOAD), No. A01 (SAVE) and No. A02 (P.ON LOAD) are the menu items which can be set only for USER1. They are not displayed with the USER2 – USER5 files.
- No. A03 (MENU LOCK) is the menu item which can be set only for the USER2 – USER5 files. It is not displayed with USER1.

Time code/user bit

Time code

The time code is used when the time code signal generated by the time code generator (time code signal generator) is to be recorded on the tape, its values are to be read by the time code reader (time code signal reader), and the absolute position of the tape is to be displayed in increments of hours, minutes, seconds and frames.

The time code is written in the sub-code area (data area) of the helical track. This enables insert editing to be conducted independently using the time code alone. In addition, the VTR's playback speed can be read from the stop mode to slow-motion playback up to high-speed play (approx. 100X normal speed).

The time code values are indicated using the display and superimpose functions.

TCR 00 : 07 : 04 : 24
↑ ↑ ↑ ↑
Hours | Minutes Seconds Frames

User bit

"User bit" refers to the 32-bit (8-digit) data frame among the time code signals which has been released to users. It enables operator numbers values to be recorded.

The alphanumeric characters which can be used for the user bit are the figures 0 to 9 and the letters A to F.

<Note>

Time code and user's bit control during tape play is exercised by the data recorded in the SBC area. The data recorded in this area includes the data that appears on the display or is superimposed on the TV monitor screen and the communication data that is transferred to the editing controller.

AJ-D850P

Recording internal/external time codes

1. Setting the internal time code

- 1** Place the VTR in the stop mode.
- 2** Set the TC/CTL switch to TC.
- 3** Set the TC INT/EXT switch to INT. (Internal time code selected)
- 4** Set the REC RUN/FREE RUN switch position.
REC RUN: The time code runs at the same time as the recording proceeds.
FREE RUN: The time code runs in the same way as the time regardless of the VTR's operation.
- 5** Set the REGEN/PRESET switch position.
REGEN: Continuity is maintained with the recorded time code before editing.
(Detailed settings are also possible using the menu settings. See the menu items below.)
Setup menu No. 503 (TCG REGEN)
Setup menu No. 504 (REGEN MODE)
PRESET: Recording starts from the value set with the TC SET button.
<Note>
During auto editing, REGEN will be selected by the setup menu No. 504 setting even if the switch has been set to the PRESET position.
- 6** Set the TC SET button.
Use the TC SET button to set the start number of the time code or user bit.
 - 1** Press the SHIFT button.
The leftmost digit flashes.
 - 2** Press the ADJ button to change the value.
Each time the button is pressed, the number changes. The setting range is given below.
 - **Time code**
00:00:00:00 – 23:59:59:29
 - **User bit**
00 00 00 00 – FF FF FF FF
 - 3** Repeat steps 1 and 2 to change the value.
 - 4** When the setting of the start number is completed, press the START button. In the FREE RUN mode, the time code now starts running.
 - 5** Proceed with the recording or editing.

2. Setting the external time code (TC switch → EXT)

- 1** Place the VTR in the stop mode.
- 2** Set the TC/CTL switch to TC.
- 3** Set the TC INT/EXT switch to EXT. (External time code selected)
- 4** Setup menu No. 505 (EXT TC SEL) can be set as follows.
LTC: The LTC signal input to the TIME CODE IN connector (XLR) on the rear jack panel is recorded as the time code.
<Note> The LTC signal must be synchronized with the video signal.
VITC: The input video signal's VITC is recorded as the time code.

AJ-D850P

Reproducing the time code/user bit

- 1** Place the unit in the stop mode.
- 2** Set the TC/CTL button to TC.
- 3** Set the TC/UB switch to TC or UB.
TC: The time code is displayed.
UB: The user bit is displayed.
 - When it is no longer possible to read the time code, it is interpolated using the CTL signal.
- 4** Press the PLAY button.
Playback now commences, and the time code appears on the display.
When setup menu No. 006 (SUPER) is ON, the time code value is superimposed onto the video signal from the VIDEO OUT 3 connector.

<Notes>

- When the time code signal cannot be read, the time code is automatically interpolated by the CTL signal.
The display appears as shown below.
- The colon between the seconds and frames changes to a period when the drop frame time code is read.

T * R 00:01:04:07

The colon between the seconds and frames changes to period during drop frame mode.

When the time code signal cannot be read, an asterisk (*) is displayed.

Superimpose screen

The control signals, time code, etc. are displayed using abbreviations.

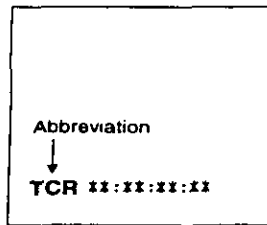

TV monitor

CTL = control signal
TCR = TC time code reading
UBR = TC user bit reading

Characters displayed

The background of characters superimposed on the display can be changed using setup menu No. 007 (CHARA TYPE).

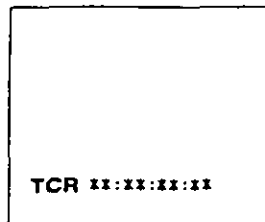

TV monitor

Display position

The position of the characters superimposed on the display can be changed using setup menus No. 001 (CHARA H-POS) and No. 002 (CHARA V-POS).

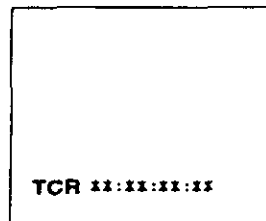

TV monitor

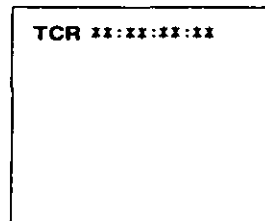

TV monitor

Operation mode

The VTR's operation mode can also be displayed using setup menu No. 003 (DISPLAY SEL).

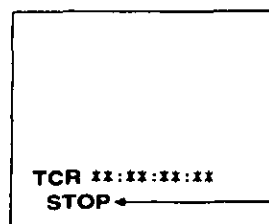

TV monitor

VTR operation mode

Servo reference

This unit automatically selects the input video signal selected by the INPUT switch, the reference video signal supplied from the REF VIDEO input connector or the internal sync signal as the servo reference signal.

When the signal is selected, the unit's mode and servo reference stand in the relationship shown in the flowchart presented below.

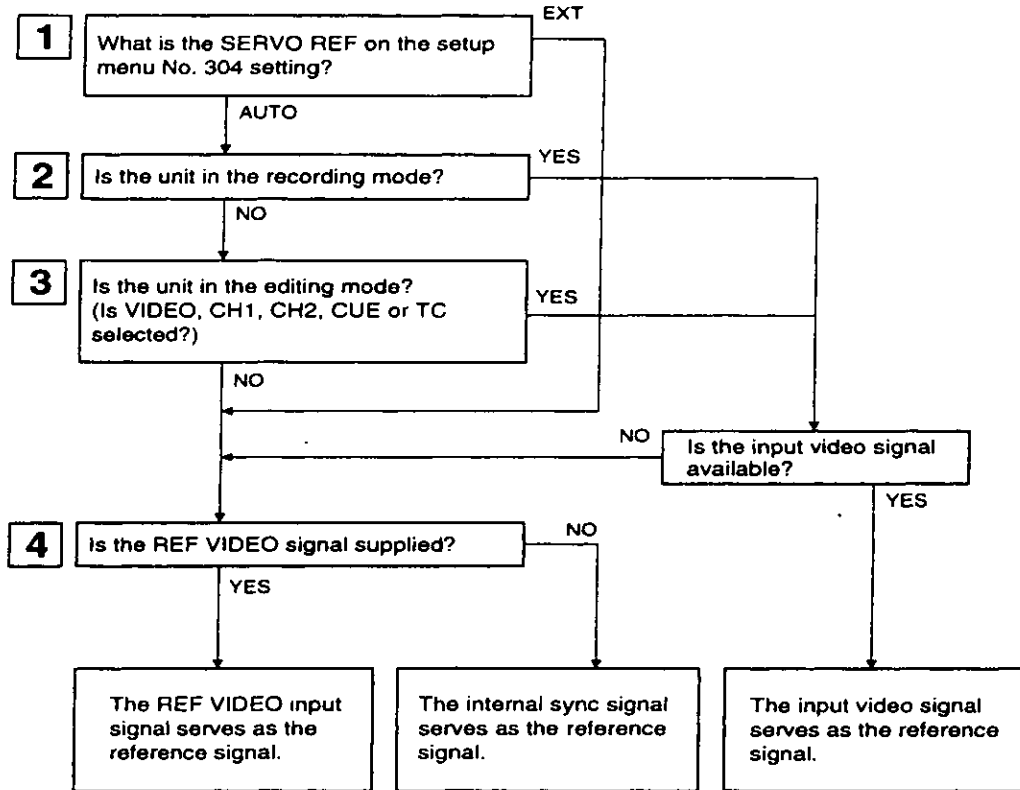

Servo reference setting tables

The servo reference signal is switched as shown in the tables below depending on the servo reference setting, deck mode and what input signal is available. When the mode is transferred to editing or recording/playback, the image may be disturbed and the transfer may be delayed if the references during playback and recording do not match.

■ During playback or special playback

SERVO REF on the setup menu No. 304 position	Input signal status		Reference signal (servo reference)
	VIDEO IN signal	REF IN signal	
AUTO	○	○	REF IN signal
	○	×	Internal sync signal
	×	○	REF IN signal
	×	×	Internal sync signal
EXT	○	○	REF IN signal
	○	×	Internal sync signal
	×	○	REF IN signal
	×	×	Internal sync signal

■ During recording or editing

SERVO REF on the setup menu No. 304 position	Input signal status		Reference signal (servo reference)
	VIDEO IN signal	REF IN signal	
AUTO	○	○	VIDEO IN signal
	○	×	VIDEO IN signal
	×	○	REF IN signal
	×	×	Internal sync signal
EXT	○	○	REF IN signal
	○	×	Internal sync signal
	×	○	REF IN signal
	×	×	Internal sync signal

"○" denotes that the signal is supplied; "x" denotes that the signal is not supplied.

Audio V Fade Function

When editing tapes, the edit point splicing selection (setup menu No. 309 and 310) information is recorded on the tape. This information is then sensed during playback, and V fade or cut processing is automatically performed for these sections. [However, only when the playback fade selection (No. 719) is AUTO.]

When the edit point splicing selection (setup menu No. 309 and 310) is CUT

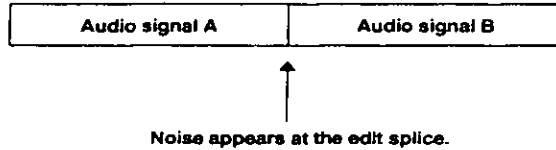

When the edit point splicing selection (setup menu No. 309 and 310) is FADE

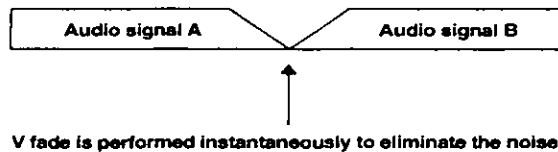

<Notes>

- When the playback fade selection (No. 719) is CUT, cut processing is performed for all splices.
- When the playback fade selection (No. 719) is FADE, V fade processing is performed for all splices.

Printed circuit board

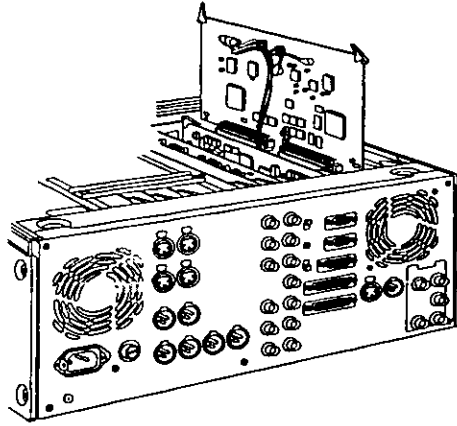

Printed circuit board	Abbr. name	Full name	Function	Factory setting
F8 board ADDA1	SW1	Audio Input Impedance SW	This sets the CH1 audio input impedance. HIGH/600Ω	HIGH
	SW41	Audio Input Impedance SW	This sets the CH2 audio input impedance. HIGH/600Ω	HIGH
H2 board CUE	SW101	Cue Input Impedance SW	This sets the CUE input impedance.	HIGH
F4 board	SW940	Component Pa/Pn Output level selector	This sets the component Pa/Pn output level when connecting with the editor. MII : MII level BETA : β-CAM level	BETA

Rack mounting

The unit can be mounted into a 19-inch standard rack if the optional rack-mounting adaptors (AJ-MA75P) are used. For the installation rails, it is recommended that the rail and bracket for 18" length (model number CC3001-99-0400) of CHASSIS TRAK be used. (The complete slide rail and bracket unit is not available from Panasonic) For further details, consult with your dealer.

- 1** Remove the screws on the left and right sides of the unit.
- 2** Use the removed screw to attach the inner members of the slide rails.

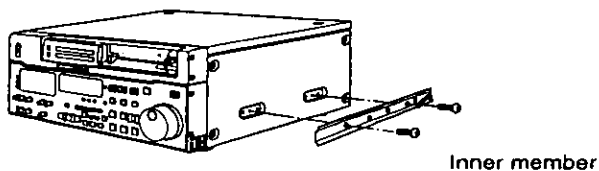

The length of the screws used is subject to restriction. If some of the mounting screws have been lost or misplaced, use screws which are less than 0.4" long in their place. Use four screws to secure each inner member.

- 3** Attach the outer member brackets to the rack. Check that the height is the same for the left and right brackets.
- 4** Attach the AJ-MA75P rack-mounting adaptors with included 4 screws.

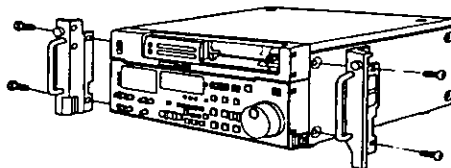

- 5** Remove the 4 rubber legs from the bottom of the unit, and install the unit in the rack. After the unit has been installed, check that it moves smoothly along the rails.

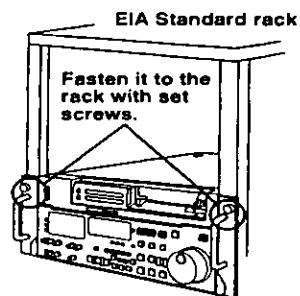

<Notes>

- Keep the temperature inside the rack to between +41°F (5°C) and +104°F (40°C).
- Bolt the rack securely to the floor so that it will not topple over when the VTR is drawn out.

Video head cleaning

This unit has an auto head cleaning function which automatically reduces the dirt on the heads. However, to further increase the unit's reliability, it is recommended that its video heads be cleaned every day.

Use the cleaning fluid designated by Panasonic.

Condensation

Condensation occurs due to the same principle involved when droplets of water form on a window pane of a heated room. It occurs when the unit or tape is moved between places where the temperature or humidity varies greatly or when, for instance:

- It is moved to a very humid place full of steam or a room immediately after it has been heated up.
- It is suddenly moved from a cold location to a hot or humid location.

When moving the unit to locations such as these, leave it standing for about 10 minutes rather than switching on the power immediately.

If condensation has formed on or in the unit, the AUTO OFF lamp lights and the cassette tape is automatically ejected.

Keep the power supplied and simply wait until the AUTO OFF lamp goes off.

Displaying the "HOURS METER" information

Turn the search dial to move the cursor (*). The description for the item where the cursor is located is shown on the counter display.

Item No.	Item	Description
H00	OPERATION	Displays the time that the power has been supplied in one-hour units.
H01	DRUM RUN	Displays the time that the drum has been rotating in one-hour units.
H02	TAPE RUN	Displays the time that the tape has been running during FF, REW, PLAY, SEARCH (JOG, VAR, SHTL), REC, and EDIT modes (except for STILL in the JOG, VAR or SHTL mode) in one-hour units.
H03	THREADING	The number of times for threading/unthreading is displayed in single units.
H11	DRUM RUN r	Displays the time that the drum has been rotating in one-hour units. (Can be reset)
H12	TAPE RUN r	Displays the time that the tape has been running during FF, REW, PLAY, SEARCH (JOG, VAR, SHTL), REC, and EDIT modes (except for STILL in the JOG, VAR or SHTL mode) in one-hour units. (Can be reset)
H13	THREADING r	The number of times for threading/unthreading is displayed in single units. (Can be reset)
H30	POWER ON	This displays the number of times the power has been turned on in 1-time increments.

<Notes>

- The resettable items in the "HOURS METER" information are reset by the shop when performing maintenance or other work.
- The search buttons and the search dial cannot be operated while the DIAG menu is displayed.

If "T&S&M" is selected in the setup menu No. 003 (DISPLAY SEL), a message appears in the mode display whenever a warning or error occurs. When multiple events occur, the event with the highest priority is displayed.

Priority	Display	Description
High ↑ ↓ Low	Error messages (See error message table)	When an abnormal operation is detected in this unit, the AUTO OFF lamp lights up and an error message is displayed.
	INT SG	If "BB" in No. 601 (INT BB SIG) in the setup menu is selected or when ON has been selected as the setup menu No. 722 (INT SG) setting, pressing the REC button or the EDIT button (E to E mode) will display "INT SG" for the first two seconds. This is also displayed for the first two seconds when starting editing.
	NO INPUT	If there is no input signal (except for analog audio) to the connector selected using the INPUT SELECT switch, pressing the REC button or the EDIT button (E to E mode) will display "NO INPUT" for the first two seconds. This is also displayed for the first two seconds when starting editing.
	Warning messages (See error message table)	When a warning occurs in this unit, the warning lamp lights up and a warning message is displayed. When multiple warnings occur, the warning with the highest priority is displayed.

Warning messages

Priority	Monitor display	Description	VTR operation
High ↑ ↓ Low	FAN STOP	This is displayed when the fan motor stops.	Operation continues
	SERVO NOT LOCKED	This is displayed when the servo is not locked for three or more seconds during playback, recording, or editing.	Operation continues
	LOW RF	This is displayed when envelope levels approximately 1/3 that of normal levels are detected for more than one second during playback, recording, or editing.	Operation continues
	HIGH ERROR RATE	This is displayed when the error rate increases and correction/interpolation is performed on either the video or audio playback signal.	Operation continues
	OVER RECORDING	When voice-over editing is performed using the internal audio memory, this message appears if the duration of the signals recorded in the memory exceeds 20 seconds.	Operation continues

Error messages

When a warning occurs in this unit, the warning lamp lights up.
Opening the DIAG menu will display the warning description on the counter display and the monitor. Also, when an abnormal operation is detected in this unit, the AUTO OFF lamp lights up and a message appears on the counter display.

DIAG menu

This display the VCR information.
VCR information includes "WARNING" information and "HOURS METER" (usage time) information. A DIAG menu appears on the monitor when the monitor is connected to the VIDEO OUT 3 connector on the connector section.

Displaying the DIAG menu

- 1** Press the DIAG button.
The DIAG menu screen is displayed on the monitor, and the message is displayed on the counter display.
- 2** The "WARNING" information and "HOURS METER" information can be switched by pressing the search buttons.
- 3** Press the DIAG button again to return to the original display.

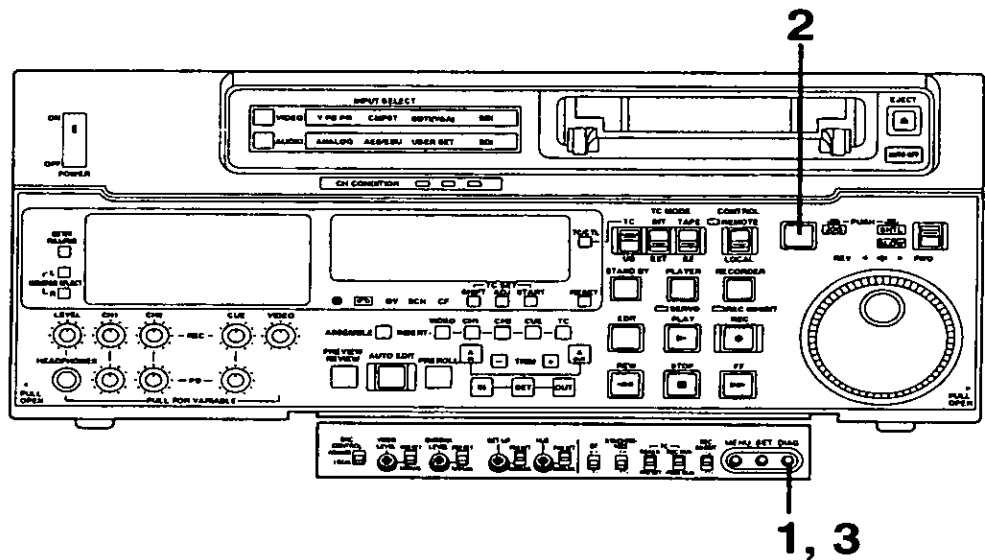

"WARNING" information display

- A warning message is displayed whenever a warning occurs (the warning lamp lights up). When warnings have not been detected, "NO WARNING" is displayed.
- When multiple warning occur, the descriptions for each warning can be checked by turning the search dial.

Table of AUTO OFF Error messages

Counter display	Monitor display	Description	VTR operation (Restart condition)
CAP ROTATE TOO SLOW	CAP ROTA TOO SLOW	If the capstan motor speed is abnormally low, the AUTO OFF lamp lights, and the message display flashes.	STOP (POWER OFF→ON)
CAP TENSION ERROR	CAP TENSION ERROR	If an abnormal tension at the supply side is detected in the capstan mode, the AUTO OFF lamp lights, and the message display flashes.	STOP (POWER OFF→ON)
DEW	DEW	If condensation is detected, the AUTO OFF lamp lights, the message display flashes, and the VTR is transferred to the eject mode. After the tape is ejected, the drum rotates in order to eliminate the condensation When the condensation has been eliminated, the AUTO OFF lamp and message display go off, and the VTR can be used. <Notes> 1) If condensation is detected in the eject mode, the drum starts rotating as soon as it is detected. 2) If condensation is detected when the cassette has been inserted, the drum rotation is stopped, and after the tape is ejected, the drum starts rotating.	EJECT (Normal operation resumed after condensation is eliminated)
DRUM ROTATE TOO FAST	DRUM ROTA TOO FAST	If the cylinder motor speed is abnormally high, the AUTO OFF lamp lights, and the message display flashes.	STOP (POWER OFF→ON)
DRUM ROTATE TOO SLOW	DRUM ROTA TOO SLOW	If the cylinder motor speed is abnormally low, the AUTO OFF lamp lights, and the message display flashes.	STOP (POWER OFF→ON)
E-FF	E-FF	If the tape start and tape end are detected simultaneously either during or after loading, the AUTO OFF lamp lights, and the message display flashes.	STOP (POWER OFF→ON)
FRONT LOAD ERROR	FRONT LOAD ERROR	The AUTO OFF lamp lights and the message display flashes when the take-up reel has been rotating idly for a fixed period of time while the start/end processing operation during loading (half position) is being performed or when it was impossible to eject the tape.	STOP (POWER OFF→ON)
FRONT LOAD MOTOR	FRONT LOAD MOTOR	If the cassette does not move up even when 6 seconds have elapsed since the VTR was transferred to the eject mode, the AUTO OFF lamp lights, and the message display flashes. <Note> If the cassette does not move down inside the machine even when 6 seconds have elapsed since the cassette was inserted, the VTR is transferred to the eject mode.	STOP (POWER OFF→ON)
LOADING MOTOR	LOADING MOTOR	When the unloading operation is not completed within 6 seconds, the AUTO OFF lamp lights, and the message display flashes. <Note> When the loading operation is not completed within 6 seconds, the VTR is transferred to the eject (unloading) mode.	STOP (POWER OFF→ON)

Counter display	Monitor display	Description	VTR operation (Restart condition)
REEL DIR UNMATCH	REEL DIR UNMATCH	If the reel motor at the take-up side is running in the reverse direction, the AUTO OFF lamp lights, and the message display flashes	STOP (POWER OFF→ON)
REEL TENSION ERROR	REEL TENSION ERROR	If an abnormal tension at the supply side is detected in the reel mode, the AUTO OFF lamp lights, and the message display flashes.	STOP (POWER OFF→ON)
SERVO COMM ERROR	SERVO COMM ERROR	When the servo microcomputer does not follow the instructions of the system control microcomputer even when 10 seconds have elapsed, the AUTO OFF lamp lights, and the message display flashes.	STOP (POWER OFF→ON)
SERVO CONTROL ERROR	SERVO CONTROL ERR	When there is no response from the servo microcomputer for 1 or more seconds, the AUTO OFF lamp lights, and the message display flashes	STOP (POWER OFF→ON)
SERVO ERROR	SERVO ERROR	When only the servo microcomputer was reset in an instantaneous power failure, the AUTO OFF lamp lights, and the message display flashes.	STOP (POWER OFF→ON)
S-FF/REW TIMEOVER	S-FF/REW TIMEOVER	If the start/end processing operation is not completed, the AUTO OFF lamp lights, and the message display flashes.	STOP (POWER OFF→ON)
S REEL ROTA TOO FAST	S REEL TOO FAST	If the supply reel motor should rotate at an abnormally fast rate, the AUTO OFF lamp lights, and the message display flashes.	STOP (POWER OFF→ON)
S REEL TORQUE ERROR	S REEL TORQUE ERR	If an abnormal torque applied to the supply reel motor is detected, the AUTO OFF lamp lights, and the message display flashes.	STOP (POWER OFF→ON)
T REEL ROTA TOO FAST	T REEL TOO FAST	If the take-up reel motor should rotate at an abnormally fast rate, the AUTO OFF lamp lights, and the message display flashes.	STOP (POWER OFF→ON)
T REEL TORQUE ERROR	T REEL TORQUE ERR	If an abnormal torque applied to the take-up reel motor is detected, the AUTO OFF lamp lights, and the message display flashes.	STOP (POWER OFF→ON)
UNLOAD ERROR	UNLOAD ERROR	If the tape has not been wound up during unloading, the AUTO OFF lamp lights, and the message display flashes.	STOP (POWER OFF→ON)
WINDUP ERROR	WINDUP ERROR	If the tape was not wound up at less than the standard speed (1x) when the total tape amount was not detected or if abnormal tape slack or tension was detected at speeds above 1x after the total tape amount was detected, the AUTO OFF lamp lights, and the message display flashes.	STOP (POWER OFF→ON)
WINDUP REEL NOT ROTA	W-UP REEL NOT ROTA	If, after the cassette has been inserted, the tape take-up reel has not wound up the tape at the standard speed (1x) or faster while the total tape amount is not detected and while the tape is traveling in the forward or reverse direction, the AUTO OFF lamp lights, and the message display flashes.	STOP (POWER OFF→ON)

RS-232C interface

1. Introduction

(1) The VTR can be operated by commands when the RS-232C interface is used.
(See command table on pages 95 – 97.)

(2) Conditions for acknowledging commands from RS-232C interface
The front panel REMOTE/LOCAL switch must be at REMOTE.
The setup menu Item No. 204 "RS232C SEL" must be ON.

If the above conditions are not met, [ACK] + [STX]ER001[EXT] is returned to the external unit.
Whether the [ACK] code is returned depends on the setting which has been selected for setup menu item No. 209 "RETURN ACK".

2. Hardware specifications

External interface specifications

1) Connector specifications

Connector: D-SUB 25-pin (crossover cable supported)

Pin No.	Signal	Circuit name	Description
1	FG	Protective ground	Frame ground
2	RXD	Received data	Data is sent to PC.
3	TXD	Transmitted data	Data is received from PC.
4	CTS	Clear to send	Shorted with pin 5.
5	RTS	Request to send	Shorted with pin 4.
6	DTR	Data terminal ready	No processing
7	SG	Signal ground	Signal ground
20	DSR	Data set ready	+ voltage output after communication enable status

2) Example of connection with controller (PC)

■ Using crossover cable with D-SUB 25-pin connectors

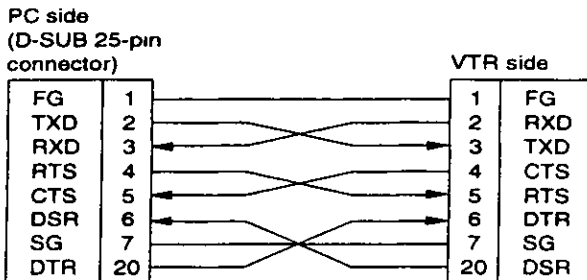

■ Using crossover cable with D-SUB 9-pin and 25-pin connectors

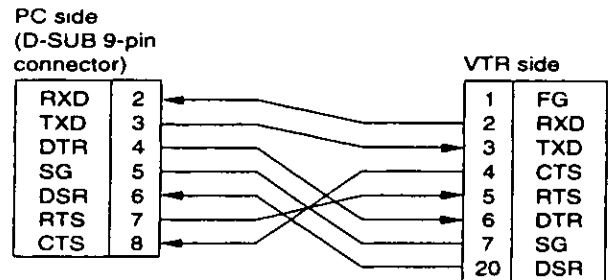

3. Software specifications

Protocol

1) Communication parameters

Communication system	Asynchronous, full duplex
Communication speed	300/600/1200/2400/4800/ <u>9600</u>
Bit length	7 bit/ <u>8 bit</u>
Stop bit	<u>1 bit</u> /2 bit
Parity bit	<u>NONE</u> /ODD/EVEN
ACK code	ACK code returned/ <u>ACK code not returned</u> <Note> The ACK code is what is returned from the VTR to the controller when data has been successfully sent from the controller.

The underlining indicates the factory settings.

Any changes to the settings can be made using the setup menu items listed below.

Communication parameter	Setup menu item
Communication speed	No. 205 BAUD RATE
Bit length	No. 206 DATA LENGTH
Stop bit	No. 207 STOP BIT
Parity bit	No. 208 PARITY
ACK code	No. 209 RETURN ACK

2) Send format [controller (PC) → VTR]

■ Data format

[STX] [command] [:] [data] [ETX]

02h XX XX XX 3Ah XX-XX 03h ←(ASCII code: symbols, numbers upper-case letters)

20h<XX<7Fh

- [command]: Command identifier; a 3-byte identifier (ASCII code: symbols, numbers, upper-case letters) is sent as the command.
- [:]: This code serves as a delimiter between the command and data.
- [data]: Data (ASCII code: symbols, numbers, upper-case letters) can be added in the number of bytes required.

■ Outline of send procedure from controller

1. The send command starts with STX (start of text = 02h). The command is then identified by COMMAND which follows and the data is added as required.
The format ends with ETX (end of text = 03h).
2. When a different command is to be sent, a response is awaited from the VTR, and then the command is sent. (See page 94.)
3. If STX is sent again before ETX is sent, the receive data buffer inside the VTR is cleared. A command error is returned to the controller, and the data is newly processed with STX which was received again at the head.

RS-232C interface

3) Return format [VTR → controller (PC)]

The following responses are made to the command. If necessary, more than one response is made.

■ When the communication has terminated normally

1. The receive completion message is returned.

[ACK]
06h

2. The execution completion message is returned.

[STX] [command] [data] [ETX]
02h XX XX XX XX-XX 03h

- [command]: This is the message (data) which is returned or the execution completion message identifier.
- [data]: This is the data to be returned. It can be omitted.

Example: Send command Return message (data)
 [STX] OPL [ETX] → [ACK] [STX] OPL [ETX]

■ When the communication has terminated abnormally

[NACK]
15h

■ When processing is not possible due to incorrect data or trouble in the VTR

1. The receive completion message is returned.

[ACK]
06h

2. An error code is returned.

[STX] E R N₁ N₂ N₃ [ETX]
02h Error code 03h

4. Error code table

ER001: Invalid command
• Unsupported command received.
• Error in command execution
ER002: Parameter error
ER102: VTR mode error (front loading motor)
ER103: VTR mode error (loading motor)
ER104: VTR mode error (drum, capstan system)
ER105: VTR mode error (reel system)
ER106: VTR mode error (tension system)
ER108: VTR dew error
ER1FF: VTR system error

5. Command table

(1) Commands relating to operation control

<Notes>

- As for the return (completion) message, [ACK] is first returned when data is received, and the execution message is subsequently returned. It is only the execution message which is listed in this table.
- In the case of commands not listed in the table, ER001 (invalid command) is returned after [ACK] has been returned.

VTR operation	Send command	Return (completion) message	Supplementary notes
STOP	[STX] OSP [ETX]	[STX] OSP [ETX]	This command is for stopping the tape travel. The resulting output picture and sound statuses differ according to the settings selected for the setup menu No. 105 (AUTO EE SEL).
EJECT	[STX] OEJ [ETX]	[STX] OEJ [ETX]	This command is for ejecting the cassette tape. The resulting output picture and sound statuses differ according to the settings selected for the setup menu No. 105 (AUTO EE SEL).
PLAY	[STX] OPL [ETX]	[STX] OPL [ETX]	This command is for starting playback.
REWIND	[STX] ORW [ETX]	[STX] ORW [ETX]	This command is for rewinding the tape. The resulting output picture and sound statuses differ according to the settings selected for the setup menu No. 105 (AUTO EE SEL). The maximum tape speed differs according to the setting selected for setup menu No. 102 (FF. REW MAX).
FAST FORWARD	[STX] OFF [ETX]	[STX] OFF [ETX]	This command is for fast forwarding the tape. The resulting output picture and sound statuses differ according to the settings selected for the setup menu No. 105 (AUTO EE SEL). The maximum tape speed differs according to the setting selected for setup menu No. 102 (FF. REW MAX).
REC	[STX] ORC [ETX]	[STX] ORC [ETX]	This command is for starting the recording.
SHTL FORWARD	[STX] OSF:data [ETX]	[STX] OSF [ETX]	This is the forward direction shuttle command.
	data = n: speed data 0: STILL 1: x0.03 (DVCPRO), x0.03 (DV, DVCAM) 2: x0.1 (DVCPRO), x0.1 (DV, DVCAM) 3: x0.2 (DVCPRO), x0.3 (DV, DVCAM) 4: x0.5 (DVCPRO), x0.5 (DV, DVCAM) 5: x1 (DVCPRO), x1 (DV, DVCAM) 6: x1.85 (DVCPRO), x1.85 (DV, DVCAM) 7: x4.1 (DVCPRO), x3.1 (DV, DVCAM) 8: x9.5 (DVCPRO), x9.5 (DV, DVCAM) 9: x16 (DVCPRO), x16 (DV, DVCAM) : This speed differs according to the setting selected for setup menu No. 101 (SHTL MAX). A: x32 (DVCPRO), x32 (DV, DVCAM) : This speed differs according to the setting selected for setup menu No. 101 (SHTL MAX).		

RS-232C interface

VTR operation	Send command	Return (completion) message	Supplementary notes
SHTL REVERSE	[STX] OSR:data [ETX]	[STX] OSR [ETX]	This is the reverse direction shuttle command.
	data = n: speed data 0: STILL 1: x0.03 (DVCPRO), x0.03 (DV, DVCAM) 2: x0.1 (DVCPRO), x0.1 (DV, DVCAM) 3: x0.2 (DVCPRO), x0.3 (DV, DVCAM) 4: x0.43 (DVCPRO), x0.5 (DV, DVCAM) 5: x1 (DVCPRO), x1 (DV, DVCAM) 6: x1.85 (DVCPRO), x1.85 (DV, DVCAM) 7: x4.1 (DVCPRO), x3.1 (DV, DVCAM) 8: x9.5 (DVCPRO), x9.5 (DV, DVCAM) 9: x16 (DVCPRO), x16 (DV, DVCAM) : This speed differs according to the setting selected for setup menu No. 101 (SHTL MAX). A: x32 (DVCPRO), x32 (DV, DVCAM) : This speed differs according to the setting selected for setup menu No. 101 (SHTL MAX).		
STANDBY OFF	[STX] OBF [ETX]	[STX] OBF [ETX]	This command is setting the VTR to standby OFF.
STANDBY ON	[STX] OBN [ETX]	[STX] OBN [ETX]	This command is setting the VTR to standby ON.

AJ-D850P

(2) Commands relating to inquiries

<Notes>

- As for the return (completion) message, [ACK] is first returned when data is received, and the execution message is subsequently returned. It is only the execution message which is listed in this table.
- In the case of commands not listed in the table, ER001 (invalid command) is returned after [ACK] has been returned.

VTR operation	Send command	Return (completion) message	Supplementary notes
CTL/TC DATA REQUEST	{STX} QCD [ETX]	[STX] CD data [ETX]	This command is for inquiring about the counter value.
		data = f w gh mm ss ff f = F w = S gh = CTL: g = SP (20h): for a plus display - (2Dh): for a minus display h = 0 - 9: hours TC: gh = 00 - 23: hours mm = 00 - 59: minutes ss = 00 - 59: seconds ff = 00 - 29: frames	CTL or TC is returned, whichever corresponds to the front display mode.
STATUS REQUEST	{STX} QOP [ETX]	[STX] xxx [ETX]	This command is for inquiring about the VTR's operation mode.
		xxx = OEJ: EJECT OFF: FAST FORWARD OPL: PLAY ORC: REC ORW: REWIND OSP: STOP (including the STANDBY ON) SRS: (IN/OUT) PREROLL OBF: STANDBY OFF OSF: SHTL FORWARD OSR: SHTL REVERSE OJG: JOG FORWARD/REVERSE OSW: VAR FORWARD/REVERSE EAE: AUTO EDIT EON: EDIT ON (MANUAL EDIT) EPV: PREVIEW ERV: REVIEW	
ID (VTR No.) REQUEST	{STX} QID [ETX]	[STX] data [ETX]	This command is for inquiring about the VTR used
		data = AJ-D850	

RS-232C interface

(3) Microsoft QuickBASIC sample program

```
CLS
STX$ = CHR$(&H2): ETX$ = CHR$ (&H3): NAK$ = CHR$(15): ACK$ = CHR$(&H6)
PRINT "**** RS-232C COMMUNICATION SAMPLE PROGRAM ****"
PRINT "Type Command 'QUIT' to quit."
PRINT

REM *** Communication Port Initial & Open ***
REM Port 1,9600Bps,No parity,8 bit data,1 stop bit
OPEN "COM1:9600,N,8,1" FOR RANDOM AS #1 LEN = 256

REM *** Input Command & Send Command ***
SendCmd:
INPUT "Input Command ="; SEND$
IF SEND$ = "QUIT" THEN GOTO ProgEnd
PRINT #1, STX$ + SEND$ + ETX$

REM *** Wait for Receive Command ***
WHILE LOC(1) = 0
    WAITKEY$ = INKEY$
    IF WAITKEY$ = "Q" THEN PRINT "**** Quit ****": GOTO ProgEnd
WEND

REM *** Receive Command ***
RecvCmd:
RCV$ = INPUT$(1, #1)
IF RCV$ = STX$ THEN RCV$ = "[Stx]"
IF RCV$ = ACK$ THEN RCV$ = "[Ack]"
IF RCV$ = NAK$ THEN RCV$ = "[Nak]"
IF RCV$ = ETX$ THEN BUFFER$ = BUFFER$ + "[Etx]": GOTO DispOut
BUFFER$ = BUFFER$ + RCV$
GOTO RecvCmd

REM *** Output Receive Command ***
DispOut:
PRINT "Receive Command ="; BUFFER$
PRINT
BUFFER$ = ""
GOTO SendCmd

REM *** End Program ***
ProgEnd:
CLOSE
END
```

MICROSOFT QUICKBASIC is a registered trade mark of Microsoft Corporation.

Connector signals

VIDEO IN

SERIAL IN (DIGITAL)	BNC × 2	Active through (Option)
Y, P _B , P _R (ANALOG)	BNC × 3	
VIDEO IN	BNC × 2	Loop-through, 75Ω termination switch provided
REF VIDEO IN	BNC × 2	Loop-through, 75Ω termination switch provided

VIDEO OUT

SERIAL OUT (DIGITAL)	BNC × 3	(Option)
Y, P _B , P _R (ANALOG)	BNC × 3	
VIDEO OUT	BNC × 3	

AUDIO IN

SERIAL IN (DIGITAL)	BNC × 2	(Option)
AUDIO IN (DIGITAL)	XLR × 2	CH1/CH2, AES/EBU format
AUDIO IN (ANALOG)	XLR × 2	CH1, CH2
CUE IN	XLR × 1	
TIME CODE IN	XLR × 1	

Pin No.	Signal
1	GND
2	HOT
3	COLD

AUDIO OUT

SERIAL OUT (DIGITAL)	BNC × 3	(Option)
AUDIO OUT (DIGITAL)	XLR × 2	CH1/CH2, AES/EBU format
AUDIO OUT (ANALOG)	XLR × 2	CH1, CH2
CUE OUT	XLR × 1	
TIME CODE OUT	XLR × 1	
MONITOR OUT	XLR × 2	L (CH1)/R (CH2)
HEADPHONES (front)	Mini-jack	

RS-422A REMOTE (9P)

REMOTE IN/OUT

Pin No.	Signal	Pin No.	Signal	Pin No.	Signal
1	FRAME GROUND	4	RECEIVE COMMON	7	TRANSMIT B
2	TRANSMIT A	5	—————	8	RECEIVE A
3	RECEIVE B	6	TRANSMIT COMMON	9	FRAME GROUND

REMOTE OUT

Pin No.	Signal	Pin No.	Signal	Pin No.	Signal
1	FRAME GROUND	4	TRANSMIT COMMON	7	RECEIVE B
2	RECEIVE A	5	—————	8	TRANSMIT A
3	TRANSMIT B	6	RECEIVE COMMON	9	FRAME GROUND

Connector signals

PARALLEL REMOTE (25P)

Pin No.	Signal	Pin No.	Signal	Pin No.	Signal
1	PLAY COMMAND	10	—————	19	STAND BY ON STATUS
2	STOP COMMAND	11	—————	20	PREROLL STATUS
3	FF COMMAND	12	≥10V, MAX 300mA	21	SERVO LOCK STATUS
4	REW COMMAND	13	PLAY STATUS	22	OPERATION ENABLE STATUS
5	REC COMMAND	14	STOP STATUS	23	—————
6	EJECT COMMAND	15	FF STATUS	24	—————
7	STAND BY COMMAND	16	REW STATUS	25	GND
8	PREROLL COMMAND	17	REC STATUS		
9	IN SET COMMAND	18	EJECT STATUS		

<Notes>

- COMMAND pins: TTL level, active low, ≥100ms edge electrical signal.
- STATUS pins: open collector, sink current 6 mA

RS-232C REMOTE (25-pin D-SUB crossover cable supported)

Pin No.	Abbreviation	Circuit	Description
1	FRAME GROUND	Protective ground	Frame ground
2	RxD	Received data	Sends data to the PC.
3	TxD	Transmitted data	Receives data from the PC.
4	CTS	Clear to send	Shorted with pin 5.
5	RTS	Request to send	Shorted with pin 4.
6	DTR	Data terminal ready	No processing
7	GND	Signal ground	Signal ground
20	DSR	Data set ready	Positive power output after communication enable status

ENCODER REMOTE (15P)

Pin No.	Signal	Pin No.	Signal	Pin No.	Signal
1	—————	6	SYSTEM H 0	11	RET GND
2	SET UP	7	SYS.SC COARSE (2)	12	—————
3	C LEVEL	8	-12V	13	—————
4	GND	9	HUE	14	SYS.SC FINE
5	+12V	10	VIDEO LEVEL	15	SYS.SC COARSE (1)

